



January 13, 2022

CANCELLATION NOTICE OF A REGULAR MEETING AND
CALL AND NOTICE OF A SPECIAL MEETING
OF THE
BURBANK-GLENDALE-PASADENA AIRPORT AUTHORITY

The Airport Authority administrative offices will be closed on Monday, January 17, 2022, in observance of Martin Luther King, Jr., Day. Therefore, the regular meeting of the Burbank-Glendale-Pasadena Airport Authority scheduled for Monday, January 17, 2022, at 9:00 a.m., in the Airport Skyroom of Hollywood Burbank Airport, 2627 N. Hollywood Way, Burbank, CA 91505, has been cancelled.

NOTICE is hereby given that a special meeting of the Burbank-Glendale-Pasadena Airport Authority will be held on Tuesday, January 18, 2022, at 9:00 a.m., in the Airport Skyroom of Hollywood Burbank Airport, 2627 N. Hollywood Way, Burbank, CA 91505.

Pursuant to Government Code Section 54953(e), members of the Commission may participate in this meeting via teleconference. In the interest of maintaining appropriate social distancing, a physical location is not being provided for the public to attend or comment. Members of the public may observe the meeting telephonically and may offer comment in real time through the following number:

Dial In: (818) 862-3332

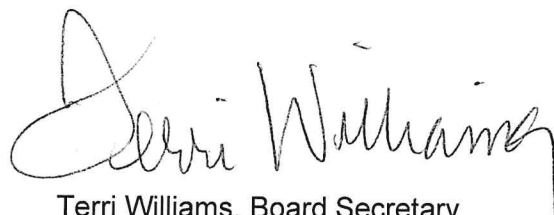
Terri Williams, Board Secretary
Burbank-Glendale-Pasadena Airport Authority

BURBANK-GLENDALE-PASADENA AIRPORT AUTHORITY

Airport Skyroom

Special Meeting of Tuesday, January 18, 2022

9:00 A.M.

The public comment period is the opportunity for members of the public to address the Commission on agenda items and on airport-related non-agenda matters that are within the Commission's subject matter jurisdiction. At the discretion of the presiding officer, public comment on an agenda item may be presented when that item is reached.



When in-person attendance or participation at meetings of the Commission is allowed, members of the public are requested to observe the following rules of decorum:

- *Turn off cellular telephones and pagers.*
- *Refrain from disorderly or boisterous conduct, including loud, threatening, profane, or abusive language, clapping, whistling, stamping, or other acts that disrupt or otherwise render unfeasible the orderly conduct of the meeting.*
- *If you desire to address the Commission during the public comment period, fill out a speaker request card and present it to the Board Secretary.*
- *Confine remarks to agenda items or to airport-related non-agenda matters that are within the Commission's subject matter jurisdiction.*
- *Limit comments to five minutes or to such other period of time as may be specified by the presiding officer.*



The following activities are prohibited:

- *Allocation of speaker time to another person.*
- *Video presentations requiring use of Authority equipment.*



Any disclosable public records related to an open session item on a regular meeting agenda and distributed by the Authority to the Commission less than 72 hours prior to that meeting are available for public inspection at Hollywood Burbank Airport (2627 N. Hollywood Way, Burbank) in the administrative office during normal business hours.



In accordance with the Americans with Disabilities Act of 1990, if you require a disability-related modification or accommodation to attend or participate in this meeting, including auxiliary aids or services, please call the Board Secretary at (818) 840-8840 at least 48 hours prior to the meeting.

AGENDA

Tuesday, January 18, 2022

1. ROLL CALL
2. PLEDGE OF ALLEGIANCE
3. APPROVAL OF AGENDA
4. PUBLIC COMMENT
5. CONSENT CALENDAR
 - a. Committee Minutes
(For Note and File)
 - 1) Operations and Development Committee
 - (i) November 15, 2021 **[See page 1]**
 - 2) Finance and Administration Committee
 - (i) November 15, 2021 **[See page 3]**
 - 3) Legal, Government and Environmental Affairs Committee
 - (i) November 15, 2021 **[See page 6]**
 - b. Commission Minutes
(For Approval)
 - 1) December 13, 2021 **[See page 8]**
 - 2) January 10, 2022 **[See page 15]**
 - c. Procurement Communications Policy **[See page 17]**
6. ITEMS FOR COMMISSION APPROVAL
 - a. Approval for Access to Install One Groundwater Monitoring Well **[See page 22]**
7. ITEMS FOR COMMISSION INFORMATION
 - a. November 2021 Passenger and Cargo Statistics **[See page 24]**
 - b. November 2021 Transportation Network Company Statistics
 - c. November 2021 Parking Revenue Statistics
 - d. Report on Replacement Passenger Terminal Ad Hoc Committee Meeting of December 20, 2021

8. CLOSED SESSION

- a. CONFERENCE WITH LEGAL COUNSEL – EXISTING LITIGATION
(California Government Code Section 54956.9(d)(1))

Name of Case: City of Los Angeles v. FAA et al. (Case No. 21-71170)

9. EXECUTIVE DIRECTOR COMMENTS

10. COMMISSIONER COMMENTS

(Other updates and information items, if any)

11. ADJOURNMENT

COMMISSION NEWSLETTER

Tuesday, January 18, 2022

[Regarding agenda items]

5. CONSENT CALENDAR

(Consent Calendar items may be enacted by one motion. There will be no separate discussion on these items unless a Commissioner so requests, in which event the item will be removed from the Consent Calendar and considered in its normal sequence on the agenda.)

- a. COMMITTEE MINUTES. Approved minutes of the Operations and Development Committee meeting of November 15, 2021; approved minutes of the Finance and Administration Committee meeting of November 15, 2021; and approved minutes of the Legal, Government and Environmental Affairs Committee meeting of November 15, 2021, are included in the agenda packet for information purposes.
- b. COMMISSION MINUTES. Draft minutes of the special December 13, 2021, Commission meeting and draft minutes of the special January 10, 2022, Commission meeting are attached for the Commission's review and approval.
- c. PROCUREMENT COMMUNICATIONS POLICY. A staff report is included in the agenda packet. At its meeting on December 13, 2021, the Legal, Government and Environmental Affairs Committee voted unanimously (3-0) to recommend that the Commission adopt the proposed Resolution No. 492 to formally establish a procurement communications policy.

6. ITEMS FOR COMMISSION APPROVAL

- a. APPROVAL FOR ACCESS TO INSTALL ONE GROUNDWATER MONITORING WELL. A staff report is included in the agenda packet. At its meeting on December 13, 2021, the Legal, Government and Environmental Affairs Committee voted unanimously (3-0) to recommend that the Commission approve to grant Lockheed Martin Corporation ("Lockheed") access to Authority property to add one Groundwater Monitoring Well outside the Air Operations Area boundary. Lockheed will bear at tis own expense all costs related to the new Well.

7. ITEMS FOR COMMISSION INFORMATION

- a. NOVEMBER 2021 PASSENGER AND AIR CARGO STATISTICS. A staff report is included in the agenda packet. The November 2021 passenger count of 483,145 was down 8% compared to November of 2019's 525,279 passengers. Also compared to November of 2019, air carrier aircraft operations in November 2021 decreased 3.5%, while cargo volume was down 1%, at 8.3 million pounds.
- b. NOVEMBER 2021 TRANSPORTATION NETWORK STATISTICS. No staff report attached. Staff will update the Commission on TNC activity for the month of November 2021.

- c. NOVEMBER 2021 PARKING STATISTICS. No staff report attached. Staff will present parking revenue data for the month of November 2021.
- d. REPORT ON REPLACEMENT PASSENGER TERMINAL AD HOC COMMITTEE MEETING OF DECEMBER 20, 2021. No staff report attached. Staff will report on the RPT Ad Hoc Committee meeting of December 20, 2021.

Approved December 13, 2021

**MINUTES OF THE REGULAR MEETING OF THE
OPERATIONS AND DEVELOPMENT COMMITTEE
BURBANK-GLENDALE-PASADENA AIRPORT AUTHORITY**

MONDAY, NOVEMBER 15, 2021

A regular meeting of the Operations and Development Committee was called to order on this date in the Airport Skyroom, 2627 N. Hollywood Way, Burbank, California, at 8:32 a.m., by Commissioner Brown.

1. ROLL CALL

Present: Commissioners Devine (via teleconference), Brown, and Hampton (via teleconference)

Absent: None

Also Present: Staff: Frank Miller, Executive Director; John Hatanaka, Senior Deputy Executive Director; Anthony DeFrenza, Director of Engineering and Maintenance

2. Approval of Agenda The agenda was approved as submitted.

3. Public Comment There were no public comments.

4. Approval of Minutes

a. October 18, 2021

b. September 20, 2021

Commissioner Devine (via teleconference) moved approval of the minutes of the October 18, Special meeting and the September 20, 2021, meeting seconded by Commissioner Brown. There being no objection, a voice vote was taken to accommodate those participating via teleconference. The motion was approved (3-0).

5. Items for Approval

a. Award of Construction Contract, Award of Professional Services Agreement, and Approval of Project Budget for Taxilane Alpha Rehabilitation-Project Number E20-02

Staff sought a Committee recommendation to the Commission for approval of the following actions:

- Award a Professional Services Agreement for \$1,197,130 to All American Asphalt for the Taxilane Alpha Rehabilitation Project;
- Award a professional services agreement for \$86,665 to RDM International, Inc. for an engineer of record services, onsite technical services, and material testing;
- Authorize a project budget for construction management, contract administration and field observation for a not-to-exceed amount of \$60,000; and,
- Authorize a project contingency of \$40,000.

Motion

Commissioner Devine (via teleconference) moved approval of Staff's recommendation, seconded by Commissioner Hampton (via teleconference).

Motion Approved

There being no objection, a voice vote was taken to accommodate those participating via teleconference. The motion was approved (3-0).

b. Award of Construction Contract, Award of Professional Services Agreement, and Approval of Project Budget for Replacement Airfield Lighting Vault

Staff sought a Committee recommendation to the Commission for approval of the following actions:

- Award a construction contract for \$4,782,907 Aldridge Electric, Inc for a replacement airfield lighting vault;
- Award a professional services agreement in the amount of \$165,385 to Lean Engineering for an engineer of record services, onsite technical services, special inspection, and material testing;
- Authorize a project budget for construction management, contract administration and field observation for a not-to-exceed amount of \$150,000;
- Authorize a project allowance for buildings permit and Burbank Water and Power fees in the amount of \$150,000;
- Authorize a project allowance of \$20,000 to provide backup generators to maintain power as needed to existing hangar tenants; and
- Authorize a project contingency of \$250,000.

Motion

Commissioner Devine (via teleconference) moved approval of Staff's recommendation, seconded by Commissioner Hampton.

Motion Approved

There being no objection, a voice vote was taken to accommodate those participating via teleconference. The motion was approved (3-0).

6. Items for Information

a. Committee Pending Items

Staff informed the Committee of future pending items that will come to the Committee for review.

7. Adjournment

There being no further business, the meeting adjourned at 9:02 a.m.

Approved December 13, 2021

**MINUTES OF THE REGULAR MEETING OF THE
FINANCE AND ADMINISTRATION COMMITTEE
BURBANK-GLENDALE-PASADENA AIRPORT AUTHORITY**

MONDAY, NOVEMBER 15, 2021

A regular meeting of the Finance and Administration Committee was called to order this date in the Airport Skyroom, 2627 N. Hollywood Way, Burbank, California, at 11:00 a.m., by Commissioner Selvidge.

1. ROLL CALL**Present:**

Commissioners Selvidge, Najarian (via teleconference), Ovrom

Absent:

None

Also Present:

Staff: John Hatanaka, Senior Deputy Executive Director; Kathy David, Deputy Executive Director, Finance and Administration; David Kwon, Director, Financial Services

Also present:

James Wilkinson, Columbia Threadneedle Investments (via teleconference); John Dempsey, Columbia Threadneedle Investments (via teleconference)

2. Staff Announcement: AB 23

The Senior Deputy Executive Director announced that, as a result of the convening of this meeting of the Finance and Administration Committee, each Committee member in attendance is entitled to receive and shall be provided \$200.

3. Approval of Agenda

Agenda was approved as presented.

Commissioner Selvidge announced that Item No. 8.a. CTI Quarterly Investment Portfolio Review would be taken after Item 5.a.

4. Public Comment

There were no public comments.

5. Approval of Minutes**a. October 18, 2021**

Draft minutes for the October 18, 2021, Finance and Administration Committee meeting were presented for approval.

Motion

Commissioner Najarian moved approval of the minutes, seconded by Commissioner Ovrom.

Motion Approved

There being no objection, a voice vote was taken to accommodate those Commissioners participating via teleconference. The motion was approved (3–0).

8. Items for Information

a. CTI Quarterly Investment Portfolio Review (July – September 2021)

Staff introduced James Wilkinson of Columbia Threadneedle Investments, the Authority’s investment advisor, who participated via teleconference.

Mr. Wilkinson and his colleague, John Dempsey, presented an update on the status of the Authority’s Operating and Passenger Facility Charge Quarterly Investment Portfolio reports ended September 30, 2021.

6. Treasurer’s Report

a. September 2021

A copy of the Treasurer’s Report for September 2021 was included in the agenda packet for the Committee’s review.

A proposed supplement to the Treasurer’s Report was introduced to the Committee which explains the Fiscal Year to Date cash expenditures of Authorized Contracts for the Replacement Passenger Terminal Project. This information will be included in the Treasurer’s Report on a quarterly basis.

Motion

Commissioner Ovrom moved approval; seconded by Commissioner Najarian.

Motion Approved

There being no objection a voice vote was taken to accommodate those participating via teleconference. The motion was approved (3–0) that it be forwarded to the Commission for note and file.

7. Items for Discussion

a. Authority Financial Procedures (Continued)

The Internal Control Procedures will be scheduled for presentation in February 2022.

b. Replacement Passenger Terminal (RPT) Financing Update

A proposed supplement to the Treasurer’s Report was introduced to the Committee which explains the Fiscal Year to Date cash expenditures of Authorized Contracts for the Replacement Passenger Terminal Project. This information will be included in the Treasurer’s Report on a quarterly basis.

Commissioner Ovrom requested to be informed periodically of the billings from the consultants.

8. Items for Information (Continued)

b. Committee Pending Items

Staff reviewed with the Committee future pending items.

Commissioner Ovrom requested an update on the billing/fee schedule and the milestone calendar from Anyone Collective, the company handling the marketing for the Airport.

9. Adjournment

There being no further business to discuss, the meeting was adjourned at 11:54 a.m.

Approved December 13, 2021

**MINUTES OF THE REGULAR MEETING OF THE
LEGAL, GOVERNMENT AND ENVIRONMENTAL AFFAIRS COMMITTEE
BURBANK-GLENDALE-PASADENA AIRPORT AUTHORITY**

MONDAY, NOVEMBER 15, 2021

A regular meeting of the Legal, Government and Environmental Affairs Committee was called to order on this date in the Burbank Room, 2627 N. Hollywood Way, Burbank, California, at 10:58 a.m., by Commissioner Agajanian.

1. ROLL CALL

Present: Commissioners Agajanian and Williams

Absent: Commissioner Gabel-Luddy

Also Present: Staff: Frank Miller, Executive Director; Patrick Lammerding, Deputy Executive Director, Planning and Development; Pamela Marcello, Senior Director, Government and Public Affairs

Authority Counsel: Terence R. Boga of Richards, Watson & Gershon and Tom Ryan of McDermott, Will & Emery

2. Staff Announcement: AB 23

The Assistant Board Secretary announced that, as a result of the convening of this meeting of the Legal, Government and Environmental Affairs Committee, each Committee member in attendance is entitled to receive and shall be provided \$200.

3. Approval of Agenda

The agenda was approved as presented.

4. Public Comment

There were no public speakers.

5. Approval of Minutes

a. October 18, 2021

Commissioner Williams moved approval of the minutes of the October 18, 2021 seconded by Commissioner Agajanian. There being no objection, the motion was approved (2-0, 1 absent).

6. Items for Approval

a. Annual Exempt Surplus Land Declaration

Staff sought a Committee recommendation to the Commission for the adoption of Resolution No. 491 to make the annual exempt surplus land declaration required by state law.

Motion

Commissioner Williams moved approval of Staff's recommendation seconded by Commissioner Agajanian.

Motion Approved

There being no objection, the motion was approved (2-0, 1 absent).

7. Items for Discussion

a. Procurement Communications Policy

At the request of a Commissioner, this item was brought to the Committee for its consideration and direction to staff whether to draft a formal policy regarding communications between interested parties and Authority representatives on business opportunities prior to and during the procurement process. At the Committees direction, Staff will present a draft policy for its consideration at a later date.

8. Items for Information

a. Committee Pending Items

Staff informed the Committee of future pending items that will come to the Committee for review

9. Closed Session

The meeting recessed to closed session at 11:11 a.m. to consider the items listed on the closed session agenda and to confer with legal counsel.

**a. CONFERENCE WITH LEGAL COUNSEL - EXISTING LITIGATION
(California Government Code Section 54956.9(d)(1))
Name of Case: City of Los Angeles v. FAA et al. (Case No. 21-71170)**

The meeting reconvened to open session at 11:19 a.m., with Commissioners Agajanian and Williams present. No reportable action taken on the presented item.

10. Adjournment

There being no further business, the meeting was adjourned at 11:20 a.m.

**MINUTES OF THE SPECIAL MEETING OF THE
BURBANK-GLENDALE-PASADENA AIRPORT AUTHORITY**

MONDAY, DECEMBER 13, 2021

A special meeting of the Burbank-Glendale-Pasadena Airport Authority was called to order this date in the Airport Skyroom, 2627 N. Hollywood Way, Burbank, California, at 9:05 a.m., by Commissioner Devine.

1. ROLL CALL

Present: Commissioners Devine (via teleconference), Brown, Agajanian, Gabel-Luddy (via teleconference), Selvidge, Ovrom, Williams, Hampton (via teleconference)

Absent: Commissioner Najarian

Also Present: Staff: Frank Miller, Executive Director; John Hatanaka, Senior Deputy Executive Director; Edward B. Skvarna, Chief, Airport Police Department and Director, Public Safety; Anthony DeFrenza, Director, Engineering and Maintenance; Nerissa Sugars, Director, Marketing Communications and Air Service; Scott Kimball, Deputy Executive Director, Operations, Business, Procurement and Safety; Tom Janowitz, Senior Manager, Ground Access

2. PLEDGE OF ALLEGIANCE Commissioner Gabel-Luddy led the Pledge of Allegiance.

3. APPROVAL OF AGENDA The agenda was approved as presented.

4. PUBLIC COMMENT There were no public comments.

5. CONSENT CALENDAR

Commissioner Ovrom requested that Item No. 5.b.1) Commission Minutes of November 15, 2021, be removed from the Consent Calendar to be discussed as a separate issue.

**a. Committee Minutes
(For Note and File)**

1) Operations and Development Committee

(i) October 18, 2021 Approved minutes of the October 18, 2021, Operations and Development Committee meeting were included in the agenda packet for information purposes.

(ii) September 20, 2021 Approved minutes of the September 20, 2021, Operations and Development Committee meeting

were included in the agenda packet for information purposes.

2) Finance and Administration Committee

(i) October 18, 2021

Approved minutes of the October 18, 2021, Finance and Administration Committee meeting were included in the agenda packet for information purposes.

3) Legal, Government and Environmental Affairs Committee

(i) October 18, 2021

Approved minutes of the October 18, 2021, Legal, Government and Environmental Affairs Committee meeting were included in the agenda packet for information purposes.

c. AB 361 Findings for Special Brown Act Requirements for Tele-conference Meetings

Included in the agenda packet was a report on AB 361 which enables local public agencies to continue to use teleconferencing without complying with certain Brown Act provisions in response to COVID-19. AB 361 states that, by majority vote, the Authority may agree that meeting in person would present imminent risks to the health or safety of attendees, and the meeting will be held via teleconference with the provision that the public will be given the opportunity to comment remotely as well.

This item will be updated and reported on a monthly basis.

d. Treasurer's Reports

1) September 2021

At its meeting on November 15, 2021, the Finance and Administration Committee reviewed the September 2021 Treasurer's Report and voted unanimously (3-0) to accept the report and recommend to the Commission for note and file.

e. Annual Exempt Surplus Land Declaration

At its meeting on November 15, 2021, the Legal, Government and Environmental Affairs Committee ("Committee") voted unanimously (3-0) to recommend the Commission adopt Resolution 491 to make the annual exempt surplus land declaration required by state law.

The California Surplus Land Act ("ACT") addresses statewide needs for affordable housing, open space, school facility, and transit village infill sites. Pursuant to the Act, prior to disposing of land, a local agency must declare the land to be "surplus land" or "exempt surplus land."

MOTION

Commissioner Agajanian moved approval of the Consent Calendar; seconded by Commissioner Gabel-Luddy.

MOTION APPROVED

There being no objection a voice vote was taken to accommodate those participating via teleconference. The motion was approved (8–0, 1 absent).

AYES: Commissioners Devine (via teleconference), Gabel-Luddy, Williams, Agajanian, Brown, Selvidge, Ovrrom, Hampton (via teleconference)

NOES: NONE

ABSENT: Commissioner Najarian

5. CONSENT CALENDAR (Continued)

**b. Commission Minutes
(For Approval)**

1) November 15, 2021

Draft minutes of the November 15, 2021, Commission meeting were included in the agenda packet for review and approval. Commissioner Ovrrom remarked on the lack of detail about public comments received and the Commission's responses. Staff explained that the meeting minutes are prepared as action minutes.

MOTION

A subsequent motion for the remainder of the Consent Calendar was made by Commissioner Williams; seconded by Commissioner Selvidge.

MOTION APPROVED

A voice vote was taken to accommodate those participating via teleconference. The motion was approved (7–1, 1 absent).

AYES: Commissioners Devine (via teleconference), Gabel-Luddy, Williams, Agajanian, Brown, Selvidge, Hampton (via teleconference)

NOES: Commissioner Ovrrom

ABSENT: Commissioner Najarian

6. ITEMS FOR COMMISSION APPROVAL

a. Award of Construction Contract, Award of Professional Services Agreement, and Approval of Project Budget for Taxilane Alpha Rehabilitation - Project No. E20-02

At its meeting on November 15, 2021, the Operations and Development Committee voted unanimously (3–0) to recommend the Commission: i) Award a construction contract in the amount of \$1,197,130 to All American Asphalt for the Taxilane Alpha Rehabilitation Project; ii) Award a professional services agreement in the amount of \$86,665 to RDM International, Inc. for an engineer of record services, onsite technical services, and material testing; iii) Authorize a project budget for construction management, contract administration and field observation for a not-to-exceed amount of \$60,000; and iv) Authorize a project contingency of \$40,000.

The pavement involved in this area services a majority of aircraft utilizing the airport.

MOTION

Commissioner Ovrom moved approval; seconded by Commissioner Hampton.

MOTION APPROVED

A voice vote was taken to accommodate those participating via teleconference. The motion was approved (8–0, 1 absent).

AYES: Commissioners Devine (via teleconference), Gabel-Luddy, Williams, Agajanian, Brown, Selvidge, Ovrom, Hampton (via teleconference)

NOES: NONE

ABSENT: Commissioner Najarian

b. Award of Construction Contract, Award of Professional Services Agreement, and Approval of Project Budget for Replacement Airfield Lighting Vault

At its meeting on November 15, 2021, the Operations and Development Committee voted unanimously (3–0) to recommend that the Commission: i) Award a construction contract in the amount of \$4,782,907 to Aldridge Electric, Inc for a replacement airfield lighting vault (“ALV”); ii) Award a professional services agreement in the amount of \$165,385 to Lean Engineering for an engineer of record services, onsite technical services, special inspection, and material testing; iii) Authorize a project budget for construction management, contract administration and field observation for a not-to-exceed amount of \$150,000; iv) Authorize a project allowance for buildings permit and Burbank Water and Power fees in the amount of \$150,000; (v) Authorize a project allowance of \$20,000 to provide backup generators to maintain power as

needed to existing hangar tenants; and vi) Authorize a project contingency of \$250,000.

Due to the sparse number of bidders involved in the project, the Commissioners requested that, in the future, a more concentrated effort be made to reach out to include more potential bidders on the project.

Commissioner Hampton requested that the bid process be agendaized for the Operations and Development Committee to discuss.

MOTION

Commissioner Ovrom moved approval; seconded by Commissioner Agajanian.

MOTION APPROVED

A voice vote was taken to accommodate those participating via teleconference. The motion was approved (8–0, 1 absent).

AYES: Commissioners Devine (via teleconference), Gabel-Luddy, Williams, Agajanian, Brown, Selvidge, Ovrom, Hampton (via teleconference)

NOES: NONE

ABSENT: Commissioner Najarian

c. Award of Contract Acquisition of Replacement Police Patrol Vehicles

At the Operations and Development Committee (“Committee”) meeting immediately preceding the Commission meeting, the Committee voted unanimously (3–0) to recommend that the Commission authorize a purchase order to National Auto Fleet Group for the acquisition of two replacement Airport Police Department (“APD”) patrol vehicles in the amount of \$117,192.73.

MOTION

Commissioner Williams moved approval; seconded by Commissioner Ovrom.

MOTION APPROVED

A voice vote was taken to accommodate those participating via teleconference. The motion was approved (8–0, 1 absent).

AYES: Commissioners Devine (via teleconference), Gabel-Luddy, Williams, Agajanian, Brown, Selvidge, Ovrom, Hampton (via teleconference)

NOES: NONE

ABSENT: Commissioner Najarian

7. ITEMS FOR COMMISSION INFORMATION

- a. **Metro Micro Service Schedule Update** Staff updated the Commission on the Metro Micro Services Schedule. This is an on-demand trip service offered by Los Angeles County which is available to passengers of Hollywood Burbank Airport.
- b. **October 2021 Passenger and Cargo Statistics** Staff presented an update on the October 2021 Passenger and Air Cargo statistics.
- c. **October 2021 Transportation Network Company Statistics** Staff presented an update on the October 2021 Transportation Network Companies' activities.
- d. **October 2021 Parking Revenue Statistics** Staff presented an update on the October 2021 Parking Revenue statistics.
- e. **Proposed Art in Public Places, Regional Intermodal Transportation Center** Staff presented to the Commission a proposed concept for the required Art in Public Places to be installed at the Regional Intermodal Transportation Center.

Staff was provided direction on a concept for the art which is to be completed in compliance with an Agreement between the City of Burbank and the Commission, and is scheduled to be in place by August 2023.

8. CLOSED SESSION

The meeting convened to Closed Session at 10:17 a.m.

a. CONFERENCE WITH LEGAL COUNSEL – EXISTING LITIGATION (California Government Code Section 54956.9(d)(1))

Name of Case: City of Los Angeles v. FAA et al. (Case No. 21-71170)

b. CONFERENCE WITH LEGAL COUNSEL – ANTICIPATED LITIGATION

Initiation of Litigation (California Government Code Section 54956.9(d)(4));
1 potential case

Meeting Reconvened to
Open Session

The meeting reconvened to open session at
10:39 a.m., with seven Commissioners present.

Closed Session Report

No reportable action taken on the presented
items.

9. EXECUTIVE DIRECTOR COMMENTS

The Executive Director informed the Commission of the following:

- The successful passenger levels achieved over the Thanksgiving holiday;

– 6 –

- Flair Airlines has begun flights to Vancouver and Edmonton;
- Staff has begun meeting with Burbank DWP to discuss the solar panel project. The outcome of these meetings will be presented to the Commission and the Burbank City Council at a later date;
- At the meeting of the Legal, Government and Environmental Affairs Committee immediately following the Commission meeting, Staff will present an amendment to the Airport Use Agreement which has been agreed upon by the Airline Airport Affairs Committee. If passed, this amendment will be presented to the Commission for approval at its next regularly scheduled meeting on January 18, 2022; and,
- In conjunction with the LA County Department of Health, the Airport had established a vaccine clinic in Terminal A to provide vaccinations for the general public. This location has been relocated in two trailers in the Valet Parking area.

**10. COMMISSIONER COMMENTS
(Other updates and information,
if any)**

Commissioner Gabel-Luddy requested a future presentation from Ms. Georgino of Georgino and Associates, providing information on the outcome of the charrettes process as it relates to the Replacement Passenger Terminal.

11. ADJOURNMENT

There being no further business, the meeting was adjourned at 10:51 a.m.

Paula Devine, President

Felicia Williams, Secretary

Date

Date

**MINUTES OF THE SPECIAL MEETING OF THE
BURBANK-GLENDALE-PASADENA AIRPORT AUTHORITY**

MONDAY, JANUARY 10, 2022

A special meeting of the Burbank-Glendale-Pasadena Airport Authority was called to order this date in the Airport Skyroom, 2627 N. Hollywood Way, Burbank, California, at 9:00 a.m., by Commissioner Devine.

1. ROLL CALL

Present: Commissioners Devine (via teleconference), Brown, Agajanian (via teleconference)(arrived 9:02), Gabel-Luddy (via teleconference), Selvidge (via teleconference), Najarian (via teleconference), Ovrom (via teleconference), Williams (via teleconference)

Absent: Commissioner Hampton

Also Present: Staff: Frank Miller, Executive Director, John Hatanaka, Senior Deputy Executive Director

2. PLEDGE OF ALLEGIANCE Commissioner Brown led the Pledge of Allegiance.

3. APPROVAL OF AGENDA The agenda was approved as presented.

4. PUBLIC COMMENT There were no public comments.

5. CONSENT CALENDAR

a. AB 361 Findings for Special Brown Act Requirements for Teleconference Meetings Included in the agenda packet was a report on AB 361 which enables local public agencies to continue to use teleconferencing without complying with certain Brown Act provisions in response to COVID-19. AB 361 states that, by majority vote, the Authority may agree that meeting in person would present imminent risks to the health or safety of attendees, and the meeting will be held via teleconference with the provision that the public will be given the opportunity to comment remotely as well.

This item will be updated and reported on monthly.

MOTION Commissioner Ovrom moved approval of the Consent Calendar; seconded by Commissioner Gabel-Luddy.

MOTION APPROVED There being no objection a voice vote was taken to accommodate those participating via teleconference. The motion was approved (8–0, 1 absent).

AYES: Commissioners Devine (via teleconference), Brown, Agajanian (via teleconference) (arrived 9:02), Gabel-Luddy (via teleconference), Selvidge (via teleconference), Najarian (via teleconference), Ovrom (via teleconference), Williams (via teleconference)

NOES: NONE

ABSENT: Commissioner Hampton

6. ADJOURNMENT

There being no further business, the meeting was adjourned at 9:03 a.m.

Paula Devine, President

Felicia Williams, Secretary

Date

Date

**STAFF REPORT PRESENTED TO THE
BURBANK-GLENDALE-PASADENA AIRPORT AUTHORITY
JANUARY 18, 2022**

PROCUREMENT COMMUNICATIONS POLICY

Prepared by Terence R. Boga
Authority General Counsel

SUMMARY

At its meeting on December 13, 2021, the Legal, Government and Environmental Affairs Committee (“Committee”) voted unanimously (3-0) to recommend that the Commission adopt the attached Resolution No. 492 to formally establish a procurement communications policy.

BACKGROUND

On November 15, 2021, the Committee discussed a request by a Commissioner that the Commission consider formally establishing a policy on business opportunity communications between interested parties and Authority representatives prior to and during the procurement process. Although there currently is not a formal policy on this subject, each Request for Qualifications (“RFQ”) and Request for Proposals (“RFP”) issued by the Authority typically includes a provision that reflects the Authority’s informal custom. Specifically, these solicitations generally include admonitions to respondents that communications during the procurement process may only be conducted through the PlanetBids portal and only with the Authority staff person administering the procurement. Additionally, when lease awards and lease renewal negotiations are ongoing, prospective and existing tenants typically are admonished that communications about the lease may only be conducted with the Authority’s negotiator.

In accordance with the Committee’s direction, staff researched procurement communications policies adopted by other agencies. Staff determined that neither the City of Burbank, the City of Glendale, nor the City of Pasadena has a formal procurement communications policy. However, like the Authority, each of these cities requires that communications be conducted solely through its purchasing/procurement department during the solicitation process. Staff also reviewed a recent Los Angeles World Airports proposal solicitation and found that the City of Los Angeles imposes a similar restriction. Finally, staff reviewed the Los Angeles Unified School District’s procurement manual. That manual includes a “cone of silence” provision stating that “any lobbying or marketing activities to District Officials by a particular bidder or its representatives must cease from the moment the solicitation is released until the time the Board Report for the final contract is posted.”

PROPOSED POLICY

The attached Resolution No. 492 is proposed to formally establish a procurement communications policy. If adopted by the Commission, this policy would govern all RFQ and RFP solicitations, including the Replacement Passenger Terminal Program progressive design builder procurement anticipated to be conducted this year. Because finding tenants for the airport’s hangars is another type of procurement regularly conducted by the Authority, the policy also has been written to address communications during negotiations for initial lease awards and lease renewals. The proposed policy states:

- Any inquiries or requests for clarification concerning an RFQ or RFP shall be in writing and submitted through the Authority's e-procurement website portal, PlanetBids, via the Q&A tab.
- During the period from RFQ or RFP issuance to the placement of a contract award recommendation on an agenda for consideration at a public meeting, respondents shall not discuss the solicitation with Commissioners or with any staff member other than the Authority's designated procurement administrator.
- During the period from commencement of lease award or lease renewal negotiations to the placement of the lease on an agenda for consideration at a public meeting, a prospective or existing tenant shall not discuss the lease with Commissioners or with any staff member other than the Authority's designated negotiator.

RECOMMENDATION

At its meeting on December 13, 2021, the Committee voted unanimously (3-0) to recommend that the Commission adopt the attached Resolution No. 492 to formally establish a procurement communications policy.

Attachment: Resolution No. 492

RESOLUTION NO. 492

**A RESOLUTION OF THE
BURBANK-GLENDALE-PASADENA AIRPORT AUTHORITY COMMISSION
ESTABLISHING A PROCUREMENT COMMUNICATIONS POLICY**

The Burbank-Glendale-Pasadena Airport Authority Commission resolves as follows:

Section 1. Findings and Intent.

A. The Burbank-Glendale-Pasadena Airport Authority (“Authority”) regularly procures special services through Request for Qualifications (“RFQ”) and Request for Proposals (“RFP”) solicitations.

B. Pursuant to informal custom, each RFQ and RFP issued by the Authority typically includes admonitions to respondents that communications about the solicitation during the procurement process may only be conducted through the PlanetBids portal and only with the Authority staff person administering the procurement.

C. The Authority regularly leases airport hangars and other property through solicitations and negotiations with prospective and existing tenants.

D. Pursuant to informal custom, the Authority typically admonishes prospective and existing tenants that communications about the lease during the negotiations may only be conducted with the Authority’s negotiator.

E. The Commission desires to formally establish a procurement communications policy to memorialize rules on allowable and prohibited communications during these procurements to prevent favoritism and preserve the integrity of the process.

Section 2. Establishment of Procurement Communications Policy. The Authority’s Procurement Communications Policy shall be as follows:

A. Any inquiries or requests for clarification concerning an RFQ or RFP shall be in writing and submitted through the Authority’s e-procurement website portal, PlanetBids, via the Q&A tab.

B. During the period from RFQ or RFP issuance to the placement of a contract award recommendation on an agenda for consideration at a public meeting, respondents shall not discuss the solicitation with Commissioners or with any staff member other than the Authority’s designated procurement administrator.

C. During the period from commencement of lease award or lease renewal negotiations to the placement of the lease on an agenda for consideration at a public meeting, a prospective or existing tenant shall not discuss the lease with Commissioners or with any staff member other than the Authority’s designated negotiator.

Section 3. Effective Date. This Resolution shall be effective upon adoption.

Adopted this ___th day of January, 2022.

Paula Devine, President
Burbank-Glendale-Pasadena Airport Authority

Attest:

Frank R. Miller, Assistant Secretary

STATE OF CALIFORNIA)
)ss.
COUNTY OF LOS ANGELES)

I, Frank R. Miller, do hereby certify that the foregoing resolution was duly and regularly adopted by the Commissioners of the Burbank-Glendale-Pasadena Airport Authority at its regular meeting held on the ___ of February 2022 by the following vote:

AYES:

NOES:

ABSENT:

**STAFF REPORT PRESENTED TO THE
BURBANK-GLENDALE-PASADENA AIRPORT AUTHORITY
JANUARY 18, 2022**

**APPROVAL FOR ACCESS TO INSTALL
ONE GROUNDWATER MONITORING WELL**

Presented by Maggie Martinez
Manager, Noise and Environmental Compliance

SUMMARY

At its meeting on December 13, 2021, the Legal, Government and Environmental Affairs Committee voted unanimously (3–0) to recommend that the Commission approve to grant Lockheed Martin Corporation (“Lockheed”) access to Authority property to add one Groundwater Monitoring Well (“Well”) outside the Air Operations Area (“AOA”) boundary. Lockheed will bear at its own expense all costs related to the new Well.

BACKGROUND

In 2017, the Authority and Lockheed executed a Miscellaneous Properties Memorandum of Understanding (“MOU”) that further memorialized Lockheed’s indemnification, defense, and remediation obligations with respect to groundwater contamination as of the date the Authority acquired the Airport, Plant C-1, and Lot C (see Exhibit I). The MOU also provided Lockheed with access to certain Groundwater Monitoring Wells at the Airport. With respect to access, the MOU states in part: “If Lockheed Martin determines to relocate any existing Groundwater Monitoring Wells . . . after consultation with and approval of the Authority, then Lockheed Martin shall bear the costs of any such relocation, including any regulatory approvals, licenses, or permits necessary for the relocated Wells . . .” (MOU, §5, pp. 2-3).

PROPOSAL

Lockheed is seeking Authority approval for access to Airport property for the purpose of installing a new Well as part of its monitoring project in the Burbank Operable Unit (“BOU”) of the San Fernando Valley Superfund sites. The new Well will be installed in the same approximate location as the current Well C-1-CW06, about 615 feet southwest of the centerline of runway 8. (Exhibit II). The new Well is needed due to the declining water levels within the San Fernando Valley, which are at risk of going dry permanently and limiting Lockheed’s ability to consistently sample Well C-1-CW06 year-over-year as required by the United States Environmental Protection Agency (“EPA”). Well C-1-CW06 consistently does not have a sufficient water column to allow for sampling. Lockheed forecasts a continued decline in the groundwater elevation, given that likely rain and corresponding groundwater levels created by rainwater runoff infiltration will continue to decline in the future due to the current drought conditions. Lockheed determined that it is necessary to add a deeper new Well adjacent to Well C-1-CW06, which can reliably sample groundwater year-over-year pursuant to EPA’s requirement. The new Well, designated as C-1-CW06R (with “R” standing for “Replacement”), will draw groundwater from a deeper depth than the exiting Well and thereby assure a more reliable water source to sample. Lockheed’s intent is to collect water samples from both Wells until Well C-1-CW06 goes dry. At that time,

Lockheed will close Well C-1-CW06 and rely solely on C-1-CW06R as a groundwater monitoring well (see Exhibit III).

Under the terms of the MOU, the Authority has discretion whether to agree to the new Well. However, the new Well is part of an EPA-approved groundwater monitoring program for the BOU area and denial of Lockheed's request could put the Authority in conflict with EPA. The monitoring in this area is designed to serve as one source of information about the overall performance of the remediation and containment plan for the BOU.

EPA has already approved Lockheed's plan to add a new Well adjacent to C-1-CW06. The new Well will be installed in accordance with the EPA-approval plan utilized for the other newly installed groundwater wells at the former Plant B-6 property. Lockheed has also provided notice of this intent to drill a new Well to the FAA, which currently has Lockheed's application under advisement (see Exhibit IV).

As part of the Well construction activities, Lockheed will temporarily place a 20 cubic yard bin to contain the soil drill cuttings in the same area of the Well construction. The bin is proposed to sit in place for approximately 30 calendar days after construction until the soil analytical data is available, and the waste disposal facility is ready to accept the soil. Once the new Well is installed, access will be required for monitoring the new Well year-over-year.

If the new Well is approved by the Commission, then a formal approval letter (see Exhibit V) will be sent to Lockheed. The letter will memorialize the terms of the approval.

FUNDING

This project is not funded by the Authority. Lockheed will bear all costs related to the new Well.

RECOMMENDATION

At its meeting on December 13, 2021, the Committee voted unanimously (3–0) to recommend that the Commission approve to grant Lockheed access to Authority property to add one Groundwater Monitoring Well outside the AOA boundary.

List of Exhibits:

Exhibit I: 2017 Miscellaneous Properties Memorandum of Understanding

Exhibit II: Figure showing the current location of Well C-1-CW06 and proposed location of Well C-1-CW06R

Exhibit III: Lockheed Access Request Letter

Exhibit IV: FAA 7460 Application

Exhibit V: Proposed Approval Letter

Hollywood Burbank Airport

REVENUE PASSENGERS	November			January - November		
	2021	2020	% Change	2021	2020	% Change

Signatory Airlines						

Alaska Airlines	41,976	10,275	308.53%	329,290	165,839	98.56%
American Airlines	39,301	14,295	174.93%	300,349	173,640	72.97%
Avelo Airlines	32,178	0	N/A	236,791	0	N/A
Delta Airlines	14,245	5,457	161.04%	143,495	70,567	103.35%
Flair Airlines	233	0	N/A	233	0	N/A
Frontier Airlines	9,870	0	N/A	63,595	0	N/A
JetBlue Airways	14,901	0	N/A	68,038	49,557	37.29%
Southwest Airlines	307,625	79,838	285.31%	2,013,803	1,299,394	54.98%
Spirit Airlines	8,298	3,850	115.53%	43,277	44,662	-3.10%
United Airlines	14,518	4,396	230.25%	63,735	96,242	-33.78%

Total Revenue Passengers	483,145	118,111	309.06%	3,262,606	1,899,901	71.73%
=====						
Inbound (deplaned)	241,705	60,160	301.77%	1,634,564	952,106	71.68%
Outbound (enplaned)	241,440	57,951	316.63%	1,628,042	947,795	71.77%

AIRCRAFT OPERATIONS	November			January - November		
	2021	2020	% Change	2021	2020	% Change

Landings & Takeoffs						
Air Carrier	5,112	2,091	144.48%	37,556	4,245	784.71%
Air Taxi	1,868	1,256	48.73%	18,026	30,352	-40.61%
General Aviation	2,658	1,964	35.34%	26,583	15,832	67.91%
Military Itinerant	30	41	-26.83%	363	18,137	-98.00%
Subtotal	9,668	5,352	80.64%	82,528	68,566	20.36%

Pass Through BUR Airspace						
Civil Local	2,621	2,516	4.17%	31,997	5,922	440.31%
Military Local	0	0	N/A	0	57,804	N/A
Subtotal	2,621	2,516	4.17%	31,997	63,726	-49.79%
=====						
Total Aircraft Operations	12,289	7,868	56.19%	114,525	132,292	-13.43%

Air Carrier: Scheduled commercial air carrier operations; including cargo operators

Air Taxi: Smaller aviation operators such as charters, commuter carriers or on-demand operators

General Aviation: Civil aviation operations for personal use

Military Itinerant: Military aviation activities

Civil Local: Civil aviation operations that pass through BUR airspace monitored by FAA ATCT at BUR.

Military Local: Military aviation operations that pass through BUR airspace monitored by FAA ATCT at BUR

Hollywood Burbank Airport

AIR CARGO (lbs.)	November			January - November		
	2021	2020	% Change	2021	2020	% Change
Signatory Airlines						
Alaska Airlines	1,699	1,669	1.80%	7,532	7,150	5.34%
American Airlines	69	1,592	-95.67%	1,653	2,793	-40.82%
Avelo Airlines						
Delta Airlines	0	0	N/A	0	49,078	-100.00%
Flair Airlines						
Frontier Airlines						
JetBlue Airways						
Southwest Airlines	422,340	133,092	217.33%	2,381,270	1,291,370	84.40%
Spirit Airlines						
United Airlines	0	0	N/A	0	1,106	-100.00%
Other Scheduled Carriers						
Federal Express	3,774,350	4,633,041	-18.53%	47,646,060	47,602,485	0.09%
United Parcel Service	3,911,793	3,854,909	1.48%	45,411,518	49,920,913	-9.03%
Charter/Contract Carriers						
Ameriflight	164,539	224,348	-26.66%	2,182,098	2,988,524	-26.98%
Total Air Cargo	8,274,790	8,848,651	-6.49%	97,630,131	101,863,419	-4.16%
Inbound (deplaned)	3,840,673	4,353,240	-11.77%	48,054,408	52,947,087	-9.24%
Outbound (enplaned)	4,434,117	4,495,411	-1.36%	49,575,723	48,916,332	1.35%

MAIL (lbs.)	November			January - November		
	2021	2020	% Change	2021	2020	% Change
American Airlines	0	0	N/A	0	6,032	-100.00%
Total Mail	0	0	N/A	0	6,032	-100.00%
Inbound (deplaned)	0	0	N/A	0	3,016	-100.00%
Outbound (enplaned)	0	0	N/A	0	3,016	-100.00%

Revenue Passengers

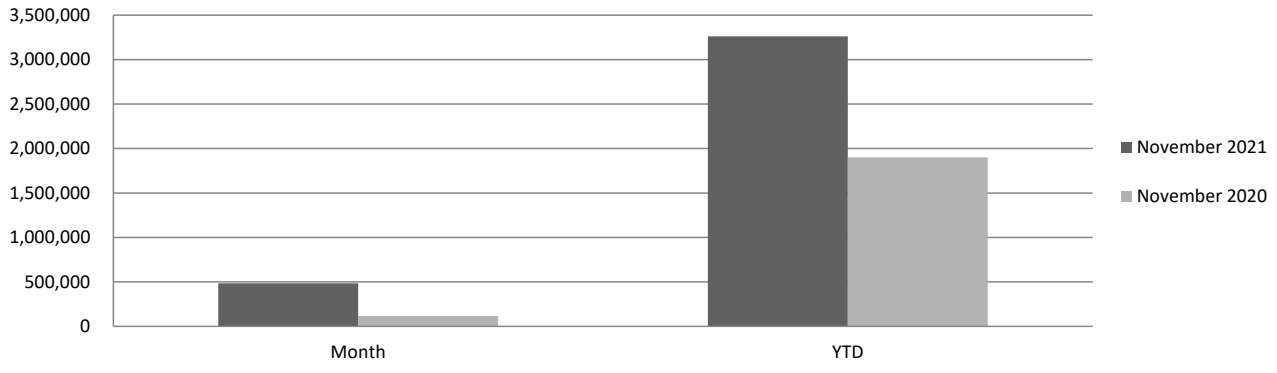

Revenue Passengers	Month	YTD
November 2021	483,145	3,262,606
November 2020	118,111	1,899,901
% Change	309.06%	71.73%

Aircraft Operations - Month

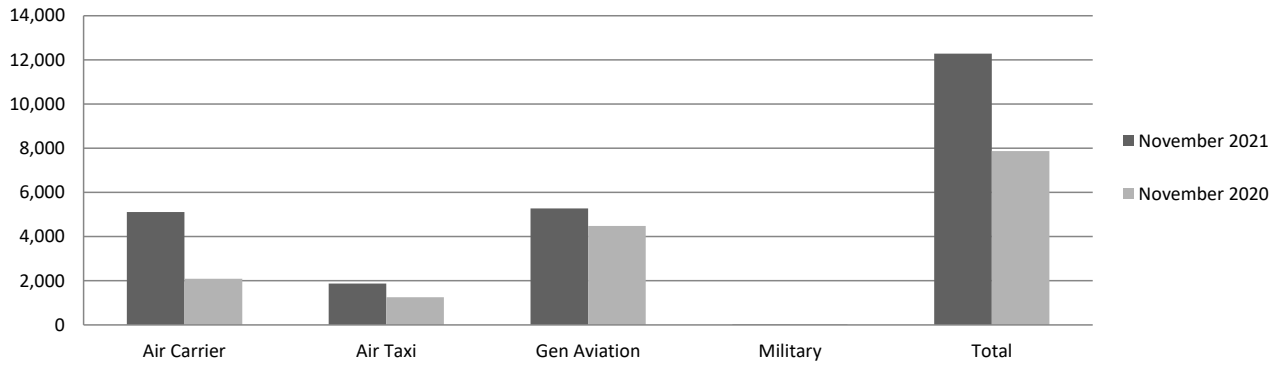

Aircraft Operations - MO	Air Carrier	Air Taxi	Gen Aviation	Military	Total
November 2021	5,112	1,868	5,279	30	12,289
November 2020	2,091	1,256	4,480	41	7,868
% Change	144.48%	48.73%	17.83%	-26.83%	56.19%

Aircraft Operations - Year-to-Date

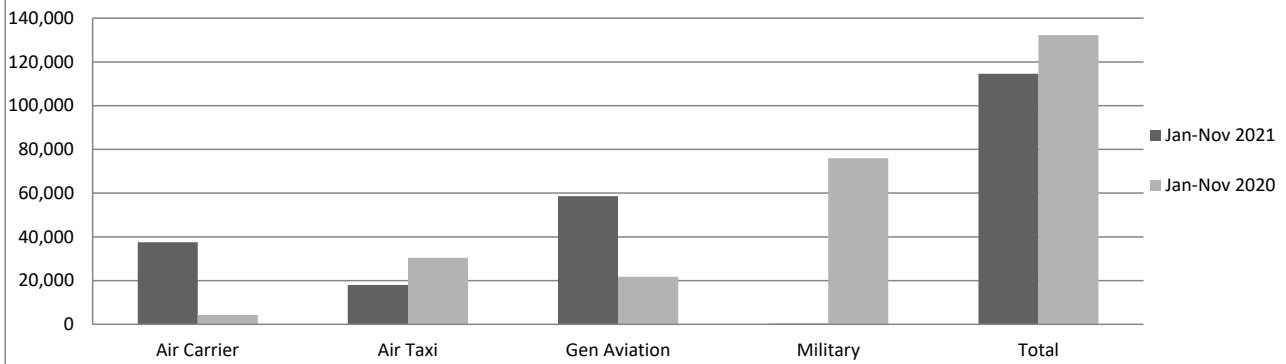

Aircraft Operations - YTD	Air Carrier	Air Taxi	Gen Aviation	Military	Total
Jan-Nov 2021	37,556	18,026	58,580	363	114,525
Jan-Nov 2020	4,245	30,352	21,754	75,941	132,292
% Change	784.71%	-40.61%	169.28%	-99.52%	-13.43%

Hollywood Burbank Airport

REVENUE PASSENGERS	November			January - November		
	2021	2019	% Change	2021	2019	% Change

Signatory Airlines						

Alaska Airlines	41,976	41,684	0.70%	329,290	560,613	-41.26%
American Airlines	39,301	32,021	22.74%	300,349	287,708	4.39%
Avelo Airlines	32,178	0	N/A	236,791	0	N/A
Delta Airlines	14,245	26,499	-46.24%	143,495	212,931	-32.61%
Flair Airlines	233	0	N/A	233	0	N/A
Frontier Airlines	9,870	0	N/A	63,595	0	N/A
JetBlue Airways	14,901	20,886	-28.66%	68,038	222,584	-69.43%
Southwest Airlines	307,625	360,137	-14.58%	2,013,803	3,766,396	-46.53%
Spirit Airlines	8,298	10,959	-24.28%	43,277	65,508	-33.94%
United Airlines	14,518	33,093	-56.13%	63,735	313,477	-79.67%
	-----	-----	-----	-----	-----	-----
Total Revenue Passengers	483,145	525,279	-8.02%	3,262,606	5,429,217	-39.91%
	=====	=====	=====	=====	=====	=====
Inbound (deplaned)	241,705	262,967	-8.09%	1,634,564	2,714,493	-39.78%
Outbound (enplaned)	241,440	262,312	-7.96%	1,628,042	2,714,724	-40.03%

AIRCRAFT OPERATIONS	November			January - November		
	2021	2019	% Change	2021	2019	% Change

Landings & Takeoffs						
Air Carrier	5,112	5,298	-3.51%	37,556	59,620	-37.01%
Air Taxi	1,868	2,070	-9.76%	18,026	20,672	-12.80%
General Aviation	2,658	2,869	-7.35%	26,583	29,621	-10.26%
Military Itinerant	30	43	-30.23%	363	495	-26.67%
Subtotal	9,668	10,280	-5.95%	82,528	110,408	-25.25%
	-----	-----	-----	-----	-----	-----
Pass Through BUR Airspace						
Civil Local	2,621	1,774	47.75%	31,997	24,110	32.71%
Military Local	0	0	N/A	0	0	N/A
Subtotal	2,621	1,774	47.75%	31,997	24,110	32.71%
	=====	=====	=====	=====	=====	=====
Total Aircraft Operations	12,289	12,054	1.95%	114,525	134,518	-14.86%

Air Carrier: Scheduled commercial air carrier operations; including cargo operators

Air Taxi: Smaller aviation operators such as charters, commuter carriers or on-demand operators

General Aviation: Civil aviation operations for personal use

Military Itinerant: Military aviation activities

Civil Local: Civil aviation operations that pass through BUR airspace monitored by FAA ATCT at BUR.

Military Local: Military aviation operations that pass through BUR airspace monitored by FAA ATCT at BUR

Hollywood Burbank Airport

AIR CARGO (lbs.)	November			January - November		
	2021	2019	% Change	2021	2019	% Change
Signatory Airlines						
Alaska Airlines	1,699	568	199.12%	7,532	8,493	-11.32%
American Airlines	69	0	N/A	1,653	213	676.06%
Avelo Airlines						
Delta Airlines	0	0	N/A	0	150	-100.00%
Flair Airlines						
Frontier Airlines						
JetBlue Airways						
Southwest Airlines	422,340	170,011	148.42%	2,381,270	1,761,384	35.19%
Spirit Airlines						
United Airlines	0	3,312	-100.00%	0	54,464	-100.00%
Other Scheduled Carriers						
Federal Express	3,774,350	3,984,668	-5.28%	47,646,060	47,206,045	0.93%
United Parcel Service	3,911,793	3,979,312	-1.70%	45,411,518	44,887,958	1.17%
Charter/Contract Carriers						
Ameriflight	164,539	214,841	-23.41%	2,182,098	2,631,675	-17.08%
Total Air Cargo	8,274,790	8,352,712	-0.93%	97,630,131	96,550,382	1.12%
Inbound (deplaned)	3,840,673	4,256,725	-9.77%	48,054,408	47,415,226	1.35%
Outbound (enplaned)	4,434,117	4,095,987	8.26%	49,575,723	49,135,156	0.90%

MAIL (lbs.)	November			January - November		
	2021	2019	% Change	2021	2019	% Change
American Airlines	0	0	N/A	0	0	#DIV/0!
Total Mail	0	0	N/A	0	0	#DIV/0!
Inbound (deplaned)	0	0	N/A	0	0	#DIV/0!
Outbound (enplaned)	0	0	N/A	0	0	#DIV/0!

Revenue Passengers

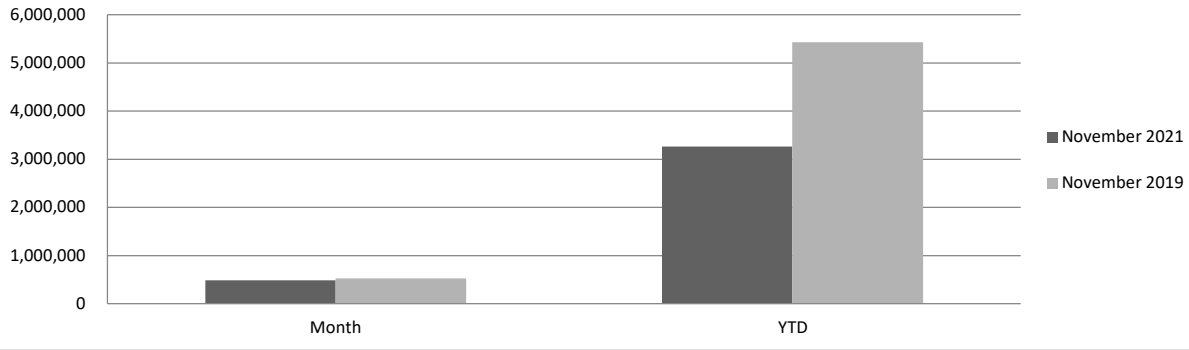

Revenue Passengers	Month	YTD
November 2021	483,145	3,262,606
November 2019	525,279	5,429,217
% Change	-8.02%	-39.91%

Aircraft Operations - Month

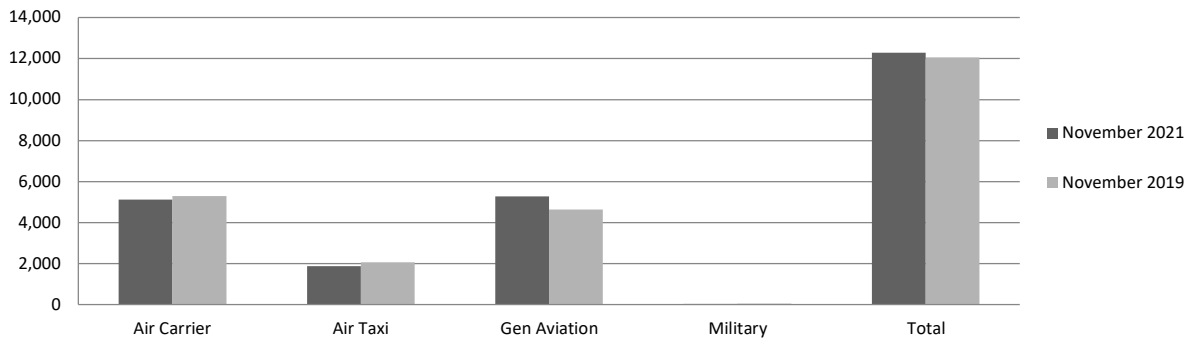

Aircraft Operations - MO	Air Carrier	Air Taxi	Gen Aviation	Military	Total
November 2021	5,112	1,868	5,279	30	12,289
November 2019	5,298	2,070	4,643	43	12,054
% Change	-3.51%	-9.76%	13.70%	-30.23%	1.95%

Aircraft Operations - Year-to-Date

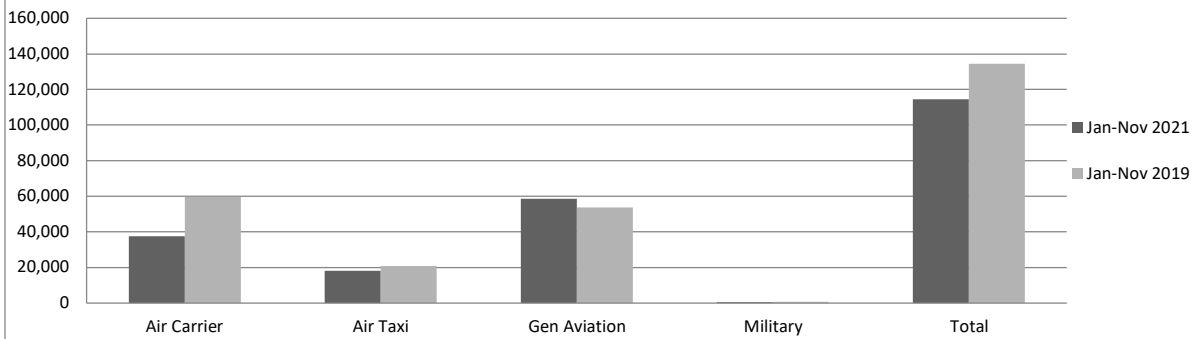

Aircraft Operations - YTD	Air Carrier	Air Taxi	Gen Aviation	Military	Total
Jan-Nov 2021	37,556	18,026	58,580	363	114,525
Jan-Nov 2019	59,620	20,672	53,731	495	134,518
% Change	-37.01%	-12.80%	9.02%	-26.67%	-14.86%

Exhibit I

MISCELLANEOUS PROPERTIES MEMORANDUM OF UNDERSTANDING BETWEEN LOCKHEED MARTIN CORPORATION AND THE BURBANK-GLENDALE-PASADENA AIRPORT AUTHORITY

This Miscellaneous Properties Memorandum of Understanding (“MOU”) between Lockheed Martin Corporation, a Maryland corporation (“Lockheed Martin”), and the Burbank-Glendale-Pasadena Airport Authority, a California joint powers agency (“the Authority”), is dated April 17, 2017 for reference purposes and is regarding access to three properties formerly designated as “Plant B-5”, “Plant C-1”, and “Parking Lot C”.

RECITALS

Whereas, Lockheed Martin is obligated, pursuant to federal and state laws, to remediate groundwater contamination emanating from Lockheed Martin’s operations in Burbank, California;

Whereas, Lockheed Martin’s continuing indemnity obligations in favor of the Authority are extant;

Whereas, in 1978 the Authority acquired through purchase certain real property formerly owned and operated by Lockheed Martin and commonly known as the Plant B-5 property;

Whereas, the acquisition of Plant B-5 was part of a larger 1978 acquisition of the entire Bob Hope Airport (the “Airport”) (then named the Hollywood-Burbank Airport, and now again currently referred to as the Hollywood Burbank Airport);

Whereas, on January 28, 1998, the Superior Court for Los Angeles County, filed a stipulated final order in condemnation in *Burbank-Glendale-Pasadena Airport Authority v. Lockheed Corporation, et al.* (Case No. BC 093432) as to certain real property formerly occupied by Lockheed Martin as the C-1 plant;

Whereas, on October 2, 1998, the Superior Court for Los Angeles County filed a final order of condemnation in *Burbank-Glendale-Pasadena Airport Authority v. Jimmie Brusso, et al.* (Case No. BC114136) as to certain real property now commonly referred to as Parking Lot C;

Whereas the Authority is entitled to certain legal statutory exclusions and defenses from potential Comprehensive Environmental Response, Compensation and Liability Act (“CERCLA”) liability by virtue of its acquisition of Plant C-1 and Parking Lot C through eminent domain; and

Whereas, the parties desire to execute this MOU in order to: (i) further memorialize Lockheed Martin’s indemnification, defense, and remediation obligations with respect to contamination stemming from its former operations; and (ii) provide for Lockheed Martin’s access to Plant B-5, Plant C-1, and Parking Lot C for monitoring of its existing groundwater monitoring wells and related activities.

NOW, THEREFORE, in consideration of Lockheed Martin’s remediation obligations and indemnity of the Authority, and the Authority’s acceptance of such indemnity and grant of future access rights to Lockheed Martin, the parties agree as follows:

1. Acknowledgement. The parties acknowledge that the Superior Court for Los Angeles County stipulated final order of condemnation filed on January 28, 1998 confirmed that Lockheed Martin Corporation had received the agreed upon payment amounts from the Authority and was a stipulating party to the final order of condemnation for Plant C-1.
2. Indemnification/Defense Obligation. Lockheed Martin shall indemnify and defend the Authority and its successors and assigns, including but not limited to tenants, lessees, ground lessees, and subsequent owners in the chain of title from the Authority, against liabilities, losses, costs or expenses arising out of claims, causes of action or suits by third parties for damages, including response costs as defined in CERCLA, caused by environmental conditions relating to groundwater contamination existing as of the date the Authority was granted possession of the Airport (1978), Plant C-1 (January 1998), and Lot C (1998).
3. Reserved Rights. Nothing in this MOU, however, shall limit or otherwise affect Lockheed Martin's rights to seek indemnity, contribution, set-off, or other reimbursement from any person who, notwithstanding a relationship with Plant C-1 and/or Plant B-5 arising after the Authority was granted possession of Plant C-1 and/or Plant B-5, is subject to liability on an independent basis, i.e., not arising from its status as an owner or operator of Plant C-1 and/or Plant B-5 under applicable federal or state law, for environmental conditions relating to groundwater contamination.
4. Remediation Obligation. Lockheed Martin remains legally responsible for the cost of any environmental remediation required by law or regulation pertaining to materials it discharged or caused to be discharged during Lockheed Martin's ownership and control of Plant B-5 and at Plant C-1. Lockheed Martin's obligations continue to exist even though it is no longer in possession of Plant B-5 or Plant C-1. Nothing in this MOU, however, legally obligates Lockheed Martin to be responsible for environmental remediation arising solely out of activities occurring after the date that the Authority obtained possession of Plant B-5, Plant C-1 or Parking Lot C.
5. Access. The Authority shall provide access to Lockheed Martin and its contractors (if Lockheed Martin and its contractors provide reasonable time and notice for such access) for Lockheed Martin to continue its monitoring of the groundwater monitoring wells designated as C-1-CW04; C-1-CW05 and C-1-CW06 (all located on former Plant B-5); C-1-CW07 and C-1-CW08 (both located on former Plant C-1), and A-1-CW08 (located on Parking Lot C). The approximate locations of each of these wells are depicted in **Exhibit A** hereto. Lockheed Martin's right to access shall begin after Lockheed Martin has demonstrated to the satisfaction of the Authority that Lockheed Martin's proposed entry and operations will comply with all Federal Aviation Administration ("FAA") regulations and guidance, including but not limited to FAA Advisory Circular 150/5370-2, "Operational Safety on Airports During Construction." The Authority is not required to provide access for additional wells or other remediation equipment. For wells or remediation equipment existing on Plant B-5, C-1 or Parking Lot C as of the date of this MOU, the Authority shall ensure alternative locations are available to Lockheed Martin if the existing locations of such wells or remediation equipment conflict with the Authority's future use of Plant B-5, Plant C-1 and/or Parking Lot C. If Lockheed Martin

determines to relocate any existing groundwater monitoring wells or other remediation equipment after consultation with and approval of the Authority, then Lockheed Martin shall bear the costs of any such relocation, including any regulatory approvals, licenses, or permits necessary for the relocated wells or remedial equipment. If the Authority leases, sells or otherwise disposes of the property on which any authorized Lockheed Martin wells are located, then the Authority will include in the transfer document a reservation of access rights in favor of Lockheed Martin. To the extent that Lockheed Martin or its contractors generate any waste as a result of additional groundwater investigations or remedial activities, then Lockheed Martin shall be solely responsible for the proper handling and disposal of all such waste and shall be listed as the disposing entity on any required waste disposal forms or manifests. The Authority's obligations under this section shall not be effective if either: (i) Lockheed Martin or its contractors fail to comply with applicable FAA regulations, safety standards or guidance; or (ii) Lockheed Martin breaches this Agreement in any other respect.

6. Closure of Wells: Upon completion of any groundwater investigation or remedial activities on Plant B-5, Plant C-1, or Parking Lot C, or upon the determination by EPA Region 9 or the Regional Water Quality Control Board-Los Angeles Region that any or all of the groundwater monitoring wells (or any additionally installed groundwater monitoring or extraction wells) may be closed by Lockheed Martin, then Lockheed Martin shall close the groundwater wells in conformance with all federal, state, and local closure requirements. Within 30 days of filing closure applications or receiving completed closure forms, Lockheed Martin shall provide the Authority with copies of such documents.
7. Data Sharing. Lockheed Martin shall make available to the Authority upon request all technical data generated as to any of the designated monitoring wells or any other Lockheed Martin-operated wells or investigations on Plant B-5, Plant C-1, and/or Parking Lot C.
8. Use. The Authority agrees it shall utilize the Plant B-5, Plant C-1, and Parking Lot C solely for industrial or commercial activity consistent with airport use zoning.
9. Term. This MOU shall remain in full force and effect until such time as it is revoked by either party with the other party's written consent.
10. Governing Law. This MOU will be governed by the laws of the State of California, except insofar as it references or incorporates references to the federal CERCLA legislation or categories of liable entities under that legislation, in which case this MOU will be interpreted and governed by federal CERCLA law provisions (42 U.S.C. Section 9601, *et. seq.*) applicable to those definitions, categories or liability standards.
11. Exhibits incorporated by reference. Exhibit A hereto is incorporated by reference and appended to this MOU.

The undersigned agree to be bound by the terms of this MOU, as attested to by signature below.

LOCKHEED MARTIN CORPORATION



Carol Cala, Vice President
Energy, Environment, Safety & Health

Approved as to form:



Beth M. Kramer
Associate General Counsel

BURBANK-GLENDALE-PASADENA AIRPORT AUTHORITY



Bill Wiggins, President

Approved as to form:



Richards, Watson & Gershon
A Professional Corporation



Ring Bender LLLP

EXHIBIT A

(attached)

Exhibit A

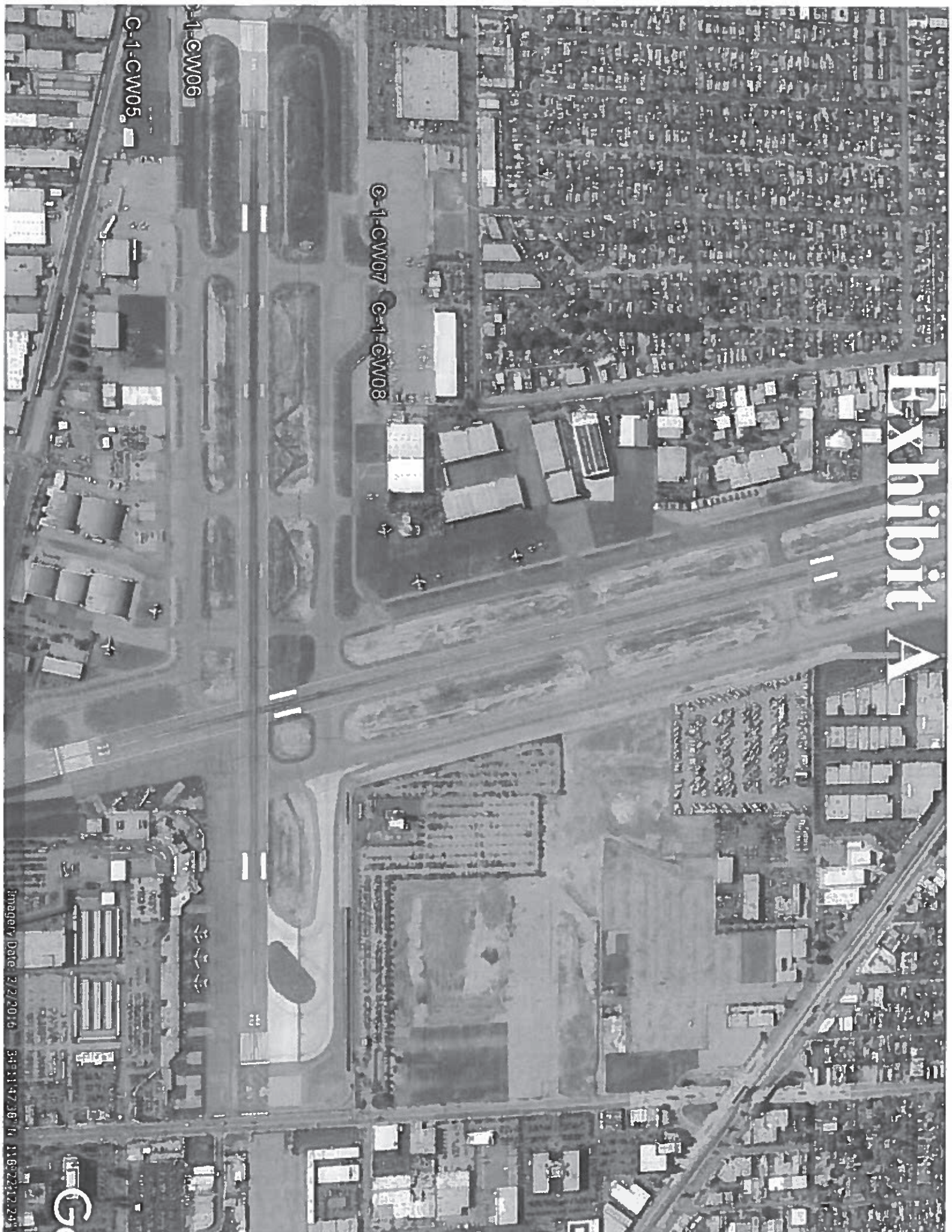

C-1-CW05

C-1-CW06

C-1-CW07 C-1-CW08



Exhibit II

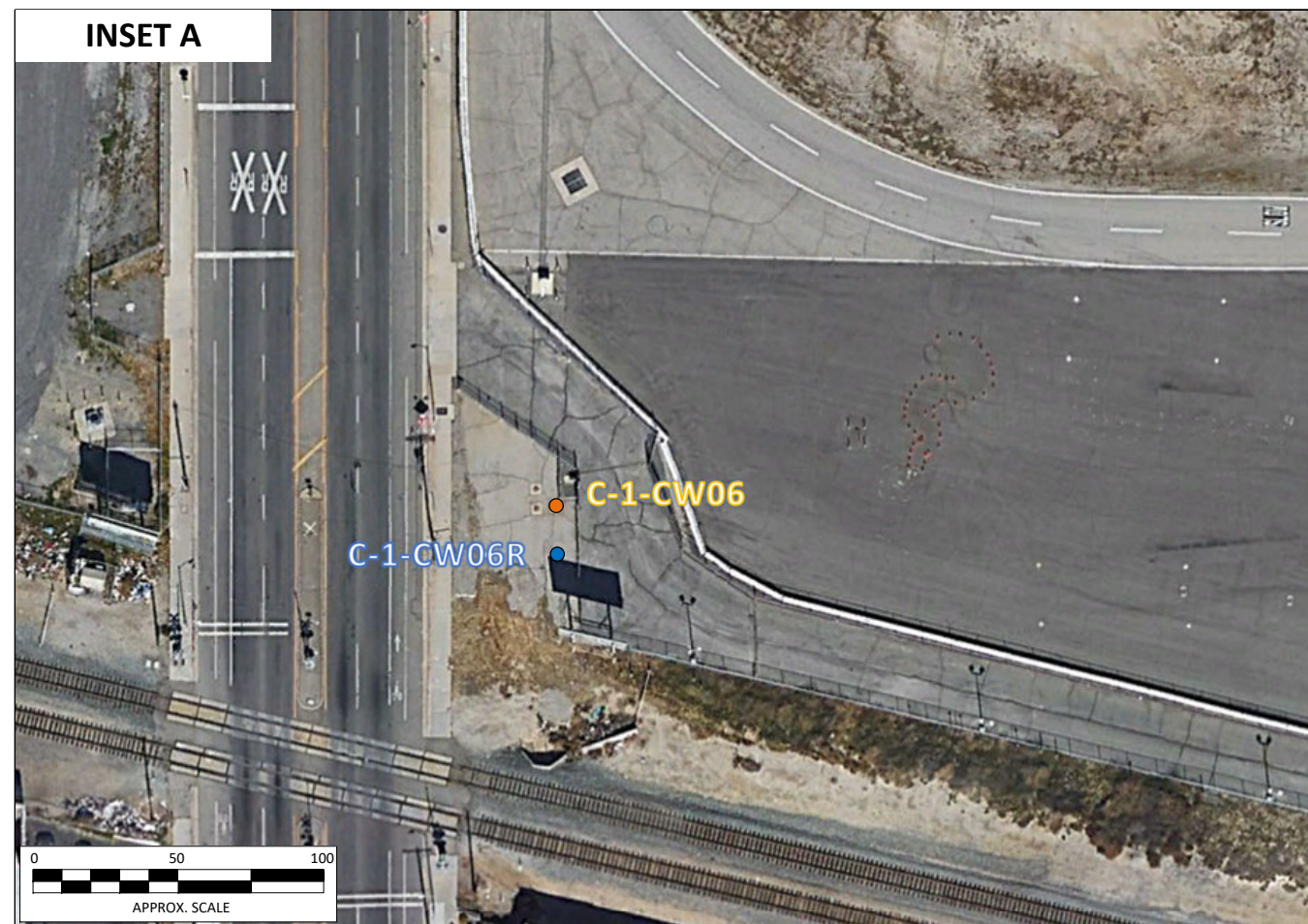
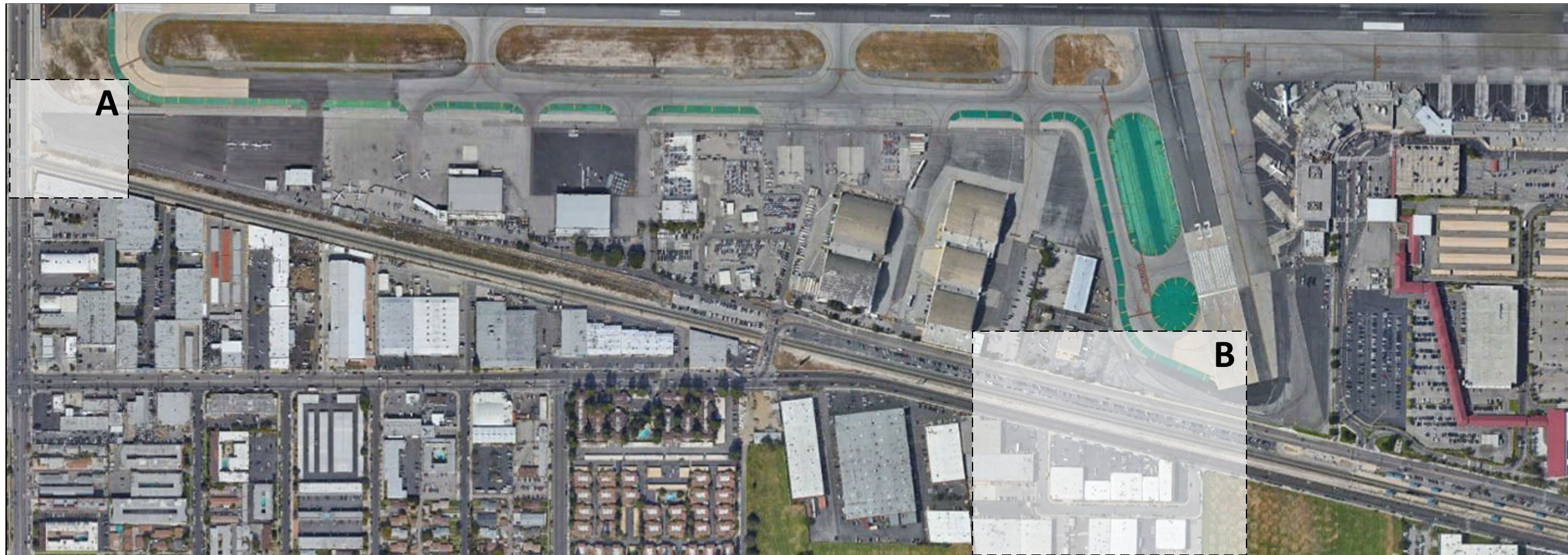

- Original A (WT) HSU Well
- Proposed Replacement Well Location

BURBANK OPERABLE UNIT

Proposed Well Replacement Locations



Lockheed Martin Corporation
Corporate Environment, Safety and Health
2550 North Hollywood Way, Suite 406 Burbank, CA 91505
Telephone: 818.847.0197 Facsimile: 818.847.0256



October 6, 2021

Mark Hardyment
Burbank-Glendale-Pasadena Airport Authority
2627 N. Hollywood Way,
Burbank, CA 91505

SUBJECT: Request for Access, Burbank Operable Unit, Burbank, California

Dear Mr. Hardyment

By this letter, Lockheed Martin Corporation ("Lockheed Martin") officially requests access to the Burbank Airport Authority ("Authority") property, pursuant to the April 17, 2017 Miscellaneous Properties Memorandum of Understanding Between Lockheed Martin Corporation and the Burbank-Glendale-Pasadena Airport Authority ("MOU"), to replace well C-1-CW06 with a new well. The new well will be in the same approximate location as C-1-CW06. See Replacement Well Plan, Exhibit A. The replacement well is needed due to declining water levels limiting the ability to consistently sample C-1-CW06 year over year, as required by United States Environmental Protection Agency ("EPA"). The EPA has approved this plan. See attached Exhibit B.

This request for access is submitted pursuant to paragraph 5 of the MOU which provides, in part:

The Authority shall provide access to Lockheed Martin and its contractors (if Lockheed Martin and its contractors provide reasonable time and notice for such access) for Lockheed Martin to continue its monitoring of the groundwater monitoring wells designated as C-I-CW04; C-I-CW05 and C-I-CW06 (all located on former Plant B-5); C-1-CW07 and C-I-CW08 (both located on former Plant C- I), and A- I-CW08 (located on Parking Lot C). . . .

If Lockheed Martin determines to relocate any existing groundwater monitoring wells or other remediation equipment after consultation with and approval of the Authority, then Lockheed Martin shall bear the costs of any such relocation, including any regulatory approvals, licenses, or permits necessary for the relocated wells or remedial equipment.

Although Paragraph 5 of the MOU does not explicitly address the process for installation of additional wells, it does state that the Authority will "ensure alternative locations are available" for replacement wells and equipment in certain circumstances. Paragraph 5 also anticipates there may be "additional remedial activities" when it discusses Lockheed Martin's responsibility for waste handling in conjunction with same.

Consistent with the intent of the MOU, Lockheed Martin has determined it is necessary to replace well C-1-CW06 with a new, deeper well, which can reliably sample groundwater year-over-year pursuant to EPA's requirements. EPA has approved Lockheed Martin's plan for replacement of well C-1-CW06 and other wells not located on Authority property. The replacement wells will be installed/constructed in accordance with the EPA-approved work plan utilized for the recent wells installed at the former Plant B-6 (Revised

Mr. Mark Hardyment
October 6, 2021
Page 2 of 2

Work Plan, Well Abandonment and Replacement, Former Plant B-6 Burbank, California, February 2019). Access for construction and development of the replacement well is estimated to be between November 22 through November 30, 2021. As part of the well construction activities, Lockheed Martin will need to temporarily place a 20 cubic yard bin to contain the soil drill cuttings in the same area of the well construction. See Well and Bin Location, Exhibit C. The bin will need to sit in place for approximately 30 calendar days after construction until the soil analytical data is available, and the waste disposal facility is ready to accept the soil. Access for the bin removal will be needed at that time. Access will then be required for monitoring the new well thereafter.

Please let us know if you have any questions or would like to schedule a call with the technical teams.

Sincerely,

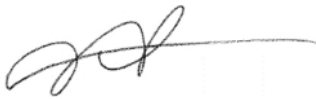

Liaht Rosenstein
Environmental Remediation Project Lead
Lockheed Martin Corporation

Enclosures: Exhibit A - Replacement Wells Plan
Exhibit B - EPA Approval of Well Replacement Plan
Exhibit C - Well and Bin Location

Cc: Beth Kramer, Lockheed Martin
Kimberly Bick, Bick Law
Robert Sabater, Tetra Tech
Maggie Martinez, BGPAA

Exhibit A
Replacement Wells Plan

Installation of Two Additional Burbank Operable Unit Monitoring Wells (B-5-CW03R and C-1-CW06R)

Because of the declining water levels within the San Fernando Valley, there are two key A (WT) HSU monitoring wells within the BOU that are at risk of going dry permanently (B-5-CW03 and C-1-CW06) – see Figure 1. These two wells do not consistently have a sufficient water column to allow for sampling and the BOU groundwater model forecasts a continued decline in the groundwater elevation (*Final Revised Site Characterization Summary/ Hydraulic Containment Evaluation Burbank Operable Unit Burbank, California, December 2020*). Although these wells do not strictly meet the criteria outlined for replacement (two consecutive years dry) because of their strategic location and the likelihood that they will meet the criteria in the next few years, Lockheed Martin proposes they be replaced in advance of the April 2022 sampling event. The two replacement wells (B-5-CW03R and C-1-CW06R) will be installed in the vicinity of the existing wells to maintain water quality data for these two areas. The existing wells will not be destroyed at this time.

Groundwater monitoring wells B-5-CW03 and C-1-CW06 were installed in 1988 as part of two three-well clusters monitoring the water table (WT), B, and older alluvium (OA) hydrostratigraphic units (HSUs). The B-5 well cluster is located just southeast of the former Plant B-5 on Union Pacific Railroad (UPRR) property and the C-1 well cluster is located in the southwest corner of the Burbank Airport property at the intersection of Vineland Avenue and the UPRR (Figure 1). A table summarizing the construction of the original WT HSU monitoring wells is attached as Table 1 and the construction logs are also attached.

Replacement Wells B-5-CW03R and C-1-CW06R - In order to determine the proposed well construction for the two replacement wells, Tetra Tech reviewed the original the well construction details, current water level data, local elevation, and the depth to the bottom of the A HSU. Table 1 presents the proposed well construction details for the two replacement wells. Figure 2 presents the proposed replacement well locations. It should be noted that the location for replacement wells B-5-CW03R is approximately 275 ft south of B-5-CW03 and on City of Burbank property (Figure 2 Inset B). This location was selected based on the limitations with installing the replacement well on the UPRR property next the original B-5 well cluster or the Burbank Airport property to the north. Replacement monitoring well C-1-CW06R will be placed within 20-25 feet of the original C-1 well cluster (Figure 2 Inset A).

When approved, it is anticipated that the permitting of these wells can be accomplished in the early fall with the installation of the wells starting immediately thereafter. The replacement wells will be installed/constructed in accordance with the USEPA-approved work plan utilized for the recent wells installed at the former Plant B-6 (Revised Work Plan, Well Abandonment and Replacement, Former Plant B-6 Burbank, California, February 2019). A brief report documenting the installation of the two replacement wells will be prepared upon completion of the task.

Figure 1 – BOU Monitoring Well Network
Figure 2 – Proposed Well Replacement Locations

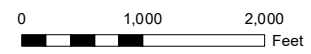
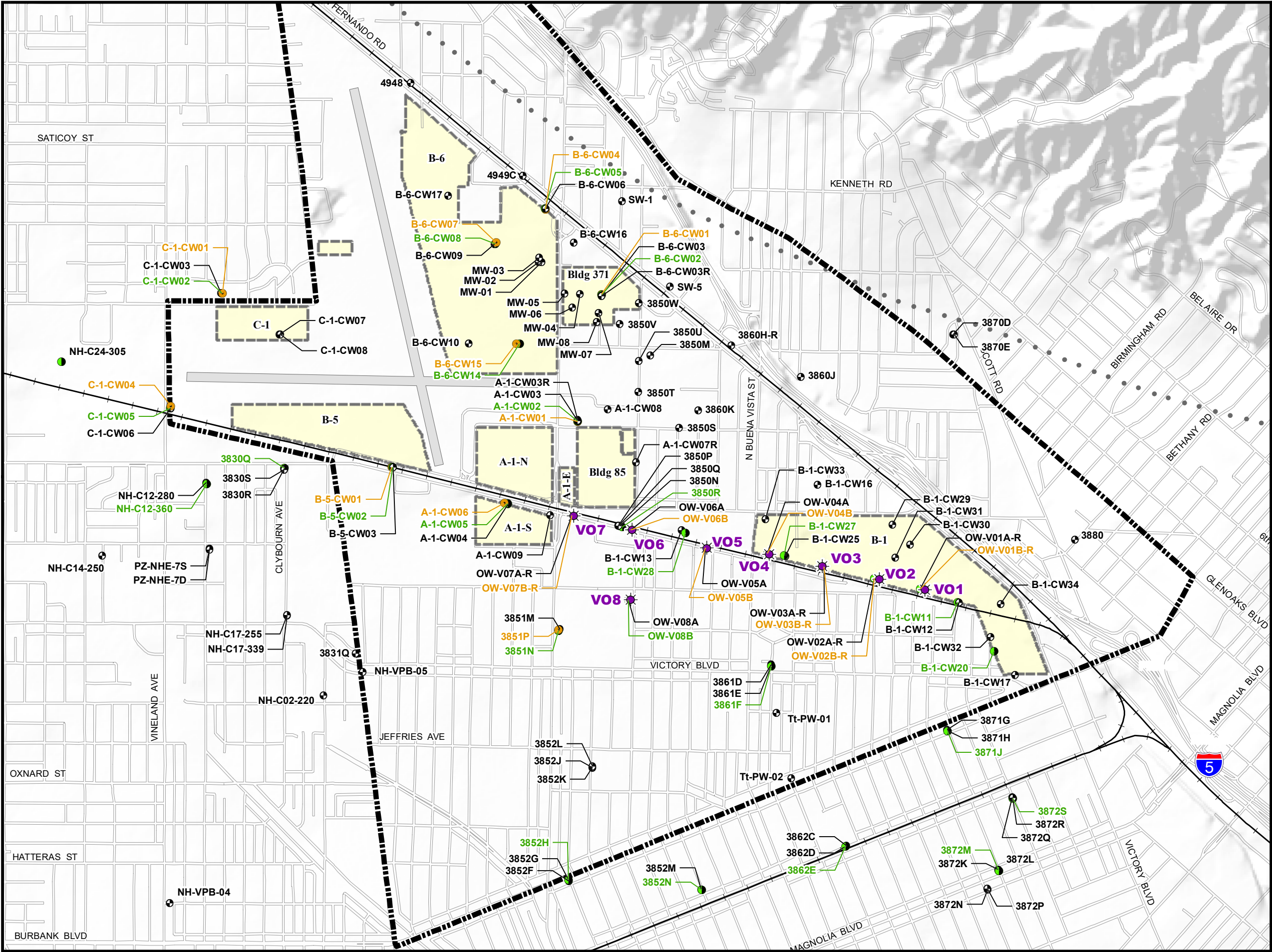

- Monitoring Well (WT-HSU)
- Monitoring Well (B-HSU)
- Monitoring Well (older alluvium)
- ✱ Extraction Well
- ⋯ Approximate Concealed Trace of the Verdugo Fault*
- Railroad
- Burbank Operable Unit Boundary
- Former Lockheed Martin Burbank Properties

Notes:
 * Bedrossian, T.L. and Roffers, P.D., 2012 "Geologic Compilation of Quaternary Surficial Deposits in Southern California, Los Angeles 30' x 60' Quadrangle (Revised)". California Geological Survey Special Report 217, Plate 9. July.

Well Survey: KDM Meridian, Inc. 2012.
 Projection: NAD83 NSRS2007 State Plane California V, FIPS0405 FT US

WT - Water Table
 B - B-Zone
 HSU - Hydrostatigraphic Unit

BURBANK OPERABLE UNIT

Monitoring Well Network



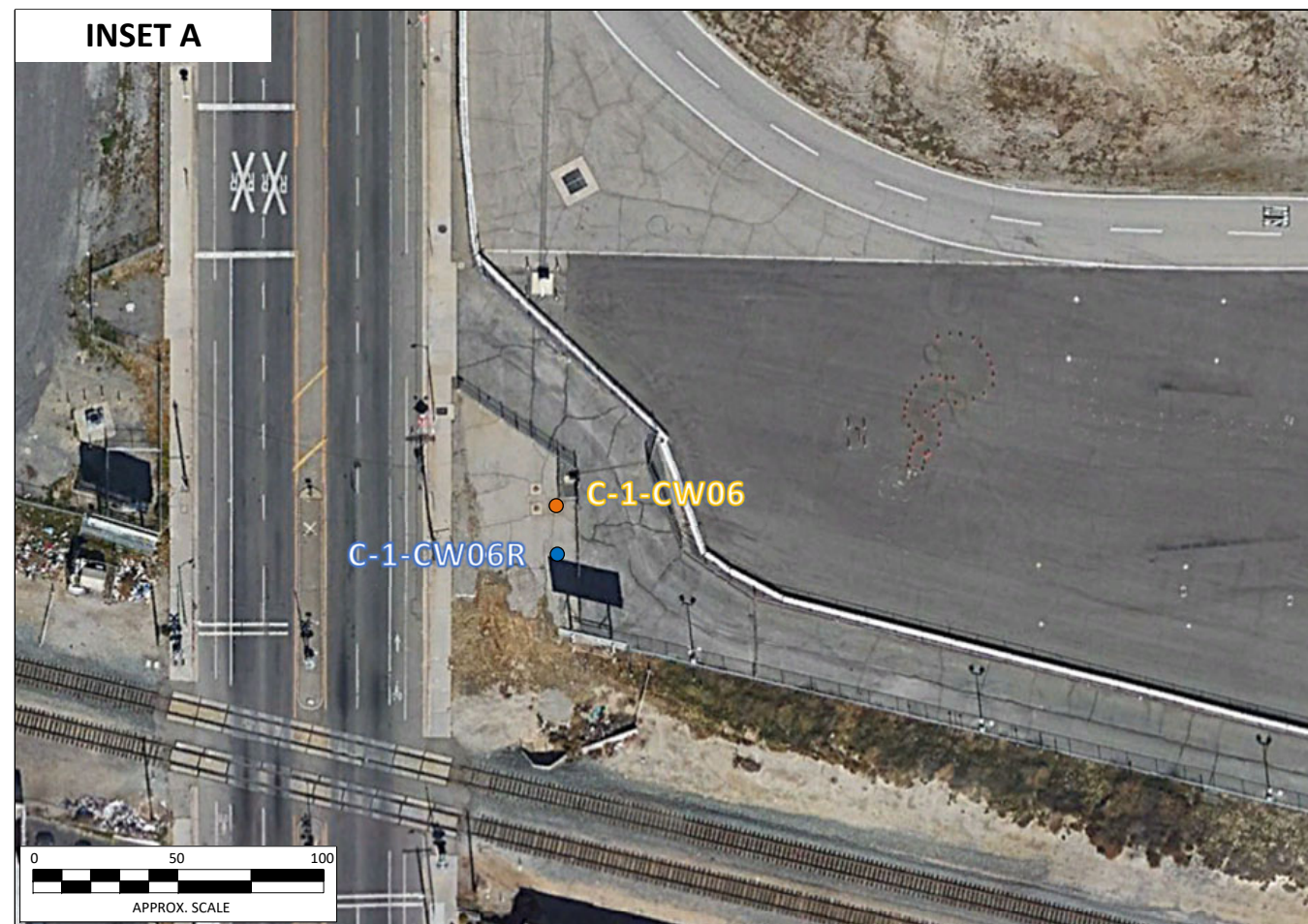
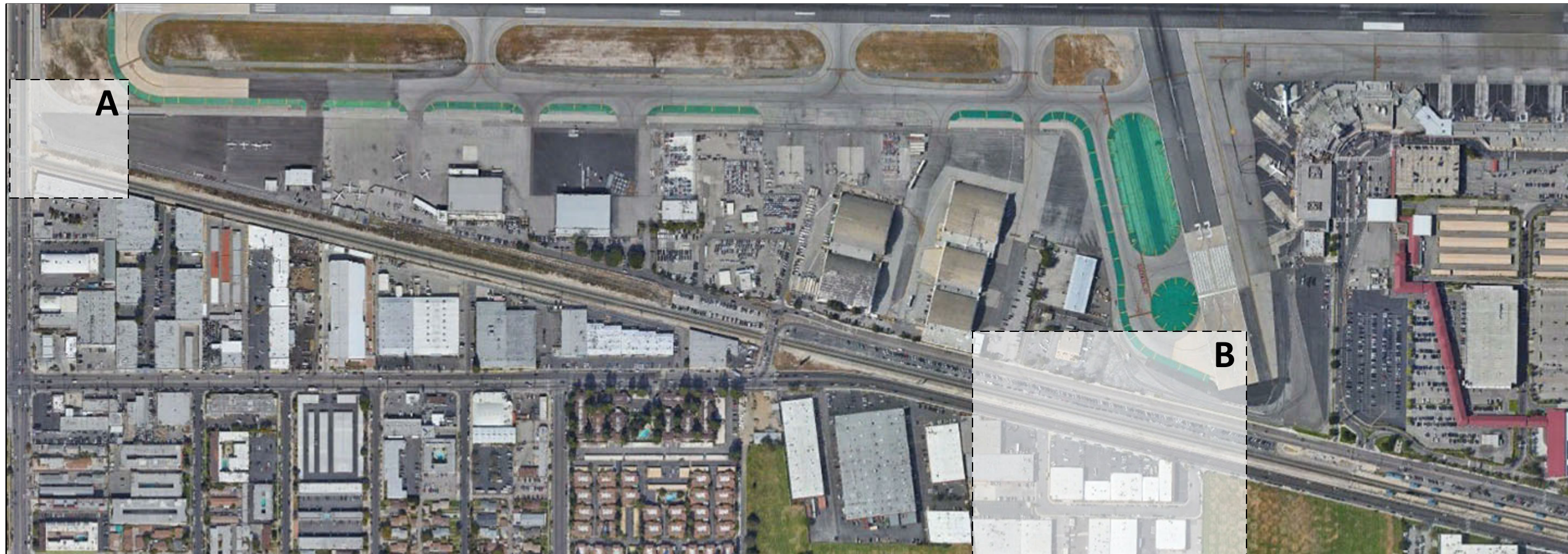

- Original A (WT) HSU Well
- Proposed Replacement Well Location

BURBANK OPERABLE UNIT

Proposed Well Replacement Locations



Table 1 – Groundwater Monitoring Well Construction

Table 1
 Burbank Operable Unit
 Groundwater Monitoring Well Construction
 Lockheed Martin Corporation
 Burbank, California

Well Identification	Date Installed	HSU	Diameter of Borehole (inches)	Depth of Borehole (feet bgs)	Casing Diameter (inches)	Blank Casing Type	Sump Length and Material (ft)	Screen Type	Top of Well Casing Elevation (feet AMSL)	Groundwater Elevation Q2 2021 (feet AMSL)	Depth to Groundwater Q4 2020 (feet below TOC)	Proposed Screen Length (ft)	Screen Interval (feet bgs)		Height of Water Column Above the Bottom of the Screen	Comments
													Top of Screen	Bottom of Screen		
B-5-CW03	6/30/1988	A	12.25	234	5	MS	NA	SS Wire-Wrapped	697.26	476.39	220.87	NA	211	231	10.13	At least 5-6 ft of water above the screen bottom is needed in order to purge and sample.
B-5-CW03R*	NA	A	10	276	4	Sch. 80 PVC	5	SS Wire-Wrapped	697.26	476.39	220.87	40	231	271	50.13	Top of Y HSU is at 280 ft bgs or 414 ft. AMSL. (HSI, 1991)
C-1-CW06	7/13/1988	A	12.25	253	5	MS	NA	SS Wire-Wrapped	720.91	484.96	235.95	NA	232	252	16.05	At least 5-6 ft of water above the screen bottom is needed in order to purge and sample.
C-1-CW06R*	NA	A	10	287	4	Sch. 80 PVC	5	SS Wire-Wrapped	720.91	484.96	235.95	30	252	282	46.05	Top of Y HSU is at 290 ft bgs or 430 ft. AMSL. (HSI, 1991)

Notes: * - proposed replacement well
 AMSL - above mean seal level
 bgs - below ground surface
 HSU - hydrostratigraphic unit
 MS - mild steel
 NA - not applicable
 ft - feet
 SS - stainless steel
 TOC - top of casing
 Highlighted values are approximate
 HSI, 1991 - Lockheed Groundwater Model Design Report. Hydro-Search, Inc. June 20.

Monitoring Well Completion Logs

- **B-5-CW03**
- **C-1-CW06**

AREA NO. 6
WELL INSTALLATION DATA
MONITORING WELL B5-CW3

ELEVATION (above MSL)

Top of Manhole 695.27'

Top of Casing 694.84'

TOTAL DEPTH OF WELL - 234'

COMPLETION DATA

Screen Interval (depth from surface) - 211' to 231'

Blank Casing Interval (depth from surface) - surface to 211'

Filter Pack Interval - 203' to 234'

Seal/Grout Intervals - Cement Grout 1' to 199'

Bentonite Grout 199' to 203'

DEPTH TO GROUNDWATER

(from top of casing)

201.94' (8-14-88)

GROUNDWATER ELEVATIONS

(above MSL)

492.90'

WELL ACTIVITIES

	Date Started	Date Completed
Drilling	6-29-88	6-29-88
Borehole Geophysical Logging	--	--
Casing, Screen and Gravel Pack	6-29-88	6-30-88
Well Developed	7-12-88	7-12-88
Well Sampled	TBA	TBA

SAMPLES

Bucket Samples were extracted at 10-foot depth intervals throughout the drilling for visual assessment and lithologic description.

B5-CW3
 AREA 6
 SCHEMATIC OF GROUNDWATER MONITORING WELL CONSTRUCTION

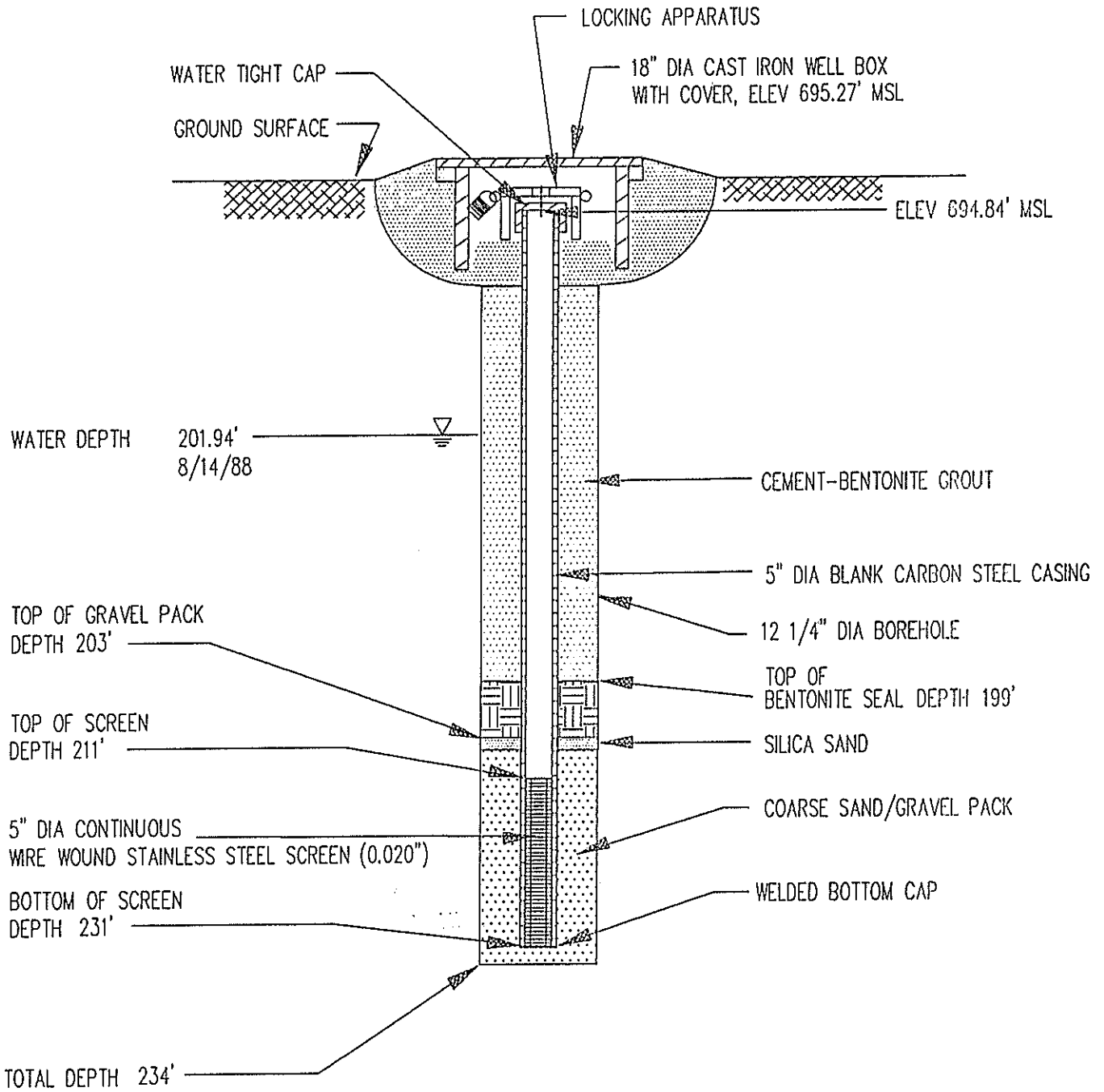

DATE COMPLETED: 6/30/88
 NOT TO SCALE

URS CONSULTANTS, INC.
 LONG BEACH, CA

AREA NO. 8
WELL INSTALLATION DATA
MONITORING WELL C1-CW6

ELEVATION (above MSL)

Top of Manhole 718.77'
Top of Casing 718.31'

TOTAL DEPTH OF WELL - 253'

COMPLETION DATA

Screen Interval (depth from surface) - 232' to 252'
Blank Casing Interval (depth from surface) - surface to 232'
Filter Pack Interval - 223' to 253'
Seal/Grout Intervals - Cement Grout 1' to 219'
 Bentonite Grout 219' to 223'

DEPTH TO GROUNDWATER

GROUNDWATER ELEVATIONS

(from top of casing)
224.48' (8-14-88)

(above MSL)
493.83'

WELL ACTIVITIES

	Date Started	Date Completed
Drilling	7-12-88	7-13-88
Borehole Geophysical Logging	--	--
Casing, Screen and Gravel Pack	7-13-88	7-13-88
Well Developed	7-20-88	7-20-88
Well Sampled	TBA	TBA

SAMPLES

Bucket Samples were extracted at 10-foot depth intervals throughout the drilling for visual assessment and lithologic description.

C1-CW6
 AREA 8
 SCHEMATIC OF GROUNDWATER MONITORING WELL CONSTRUCTION

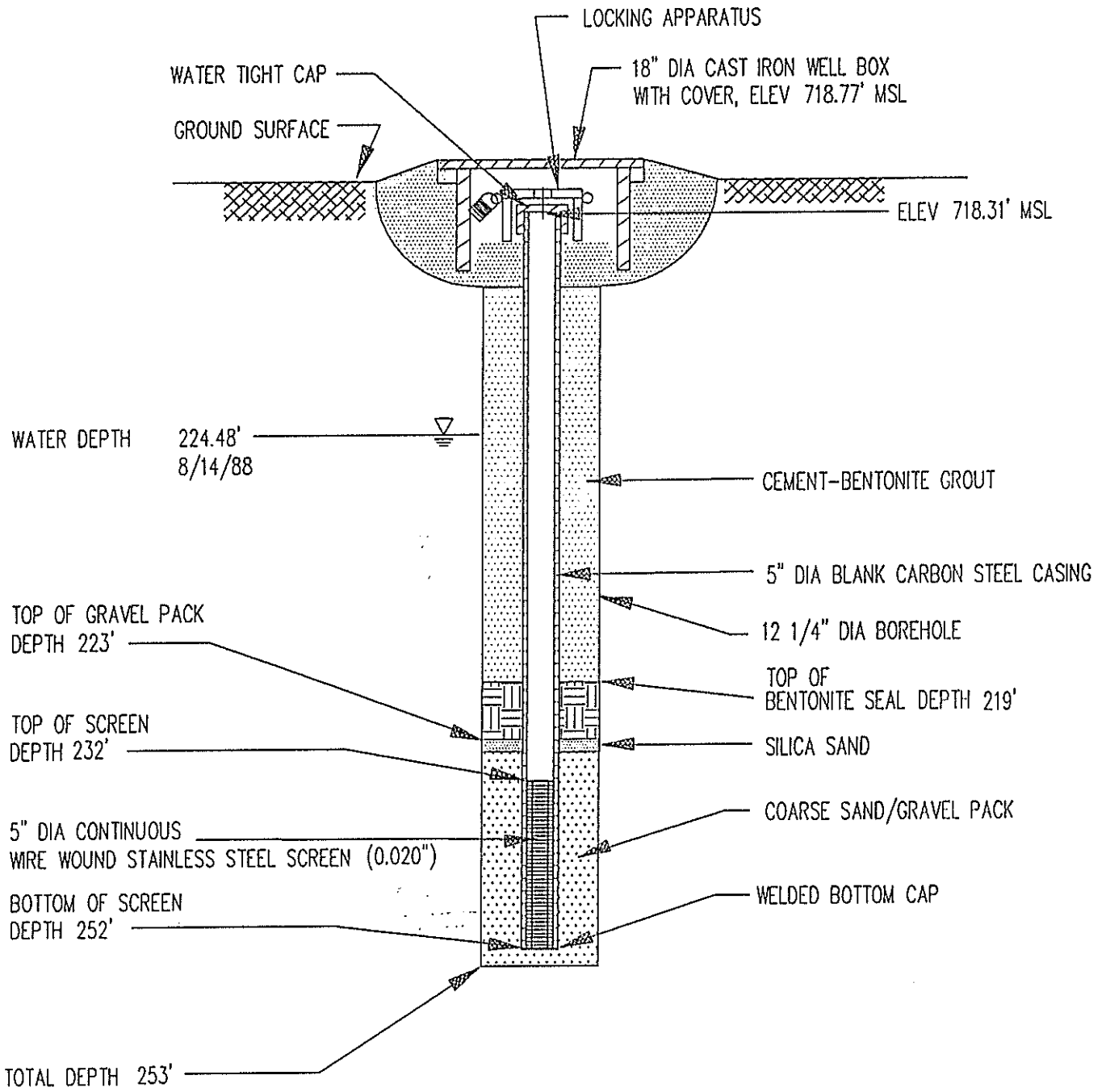

DATE COMPLETED: 7/13/88
 NOT TO SCALE

URS CONSULTANTS, INC.
 LONG BEACH, CA

Exhibit B
EPA Approval of Well Replacement Plan



Cell 303-335-5489
liaht.rosenstein@lmco.com

NOTICE - This communication may contain confidential and privileged information that is for the sole use of the intended recipient. Any viewing, copying or distribution of, or reliance on this message by unintended recipients is strictly prohibited. If you have received this message in error, please notify us immediately by replying to the message and deleting it from your computer.

Exhibit C
Well and Bin Location



LEGEND

-  Proposed location for C-1-CW06R
-  Existing Monitoring Wells (C-1-CW04, C-1-CW05, C-1-CW06)
-  Proposed Soil Bin Placement

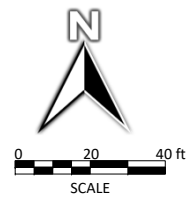

**Proposed Location for C-1-CW06R
And Soil Bin Placement**

Prepared By: RS
Reviewed By: RS
Date: Oct 2021





Archive Search Results: Notice of Proposed Construction or Alteration - On Airport

For information only.

This proposal has not yet been studied. Study outcomes will be posted at a later date.
Public comments are not requested, and will not be considered at this time.

Overview		Received Date: 10/05/2021	
Study (ASN): 2021-AWP-3761-NRA		Entered Date: 10/05/2021	
Prior Study: 2020-AWP-293-NRA		Map: View Map	
Status: Proposed			
Construction / Alteration Information		Case Information	
Notice Of: Construction		Component Type: OTHER	
Duration: Temporary		Development Type: OTHER - Miscellaneous	
if Temporary : Months: 0 Days: 14		Other Desc: Temporary Drilling Rig	
Work Schedule - Start: 11/22/2021		Prior Study: 2020-AWP-293-NRA	
Work Schedule - End: 12/03/2021		Date Determined:	
		Letters: None	
Structure Details		Common Frequency Bands	
Nearest State: CA		Low Freq	High Freq
Loc ID: BUR		Freq Unit	ERP
Airport: BOB HOPE		ERP Unit	
City: BURBANK			
Latitude: 34-11-47.01 N			
Longitude: 118-22-12.48 W			
Horizontal Datum: NAD83			
Site Elevation (SE): 720 (nearest foot)			
Structure Height (AGL): 25 (nearest foot)			
Describe/Remarks		Specific Frequencies	
Lockheed Martin will be installing a groundwater monitoring well located approx. 615 ft southwest of the centerline of BUR runway 8. To construct the well, a sonic drill rig will be used (mast height 25 ft above ground).			



January 18, 2021

Liaht Rosenstein
Environmental Remediation Project Lead
Lockheed Martin Corporation
Corporate Environment, Safety and Health
2550 North Hollywood Way, Suite 406
Burbank, California 91505

Re: BGPAA Approval of Well Replacement

Dear Ms. Rosenstein:

I write to inform you that on December 13, 2021, the Burbank-Glendale-Pasadena Airport Authority ("Authority") Commission approved Lockheed Martin's request to install a new, deeper groundwater monitoring well at the approximate location of existing well C-1-CW06, roughly 615 feet southwest of the centerline of runway 8 (the "Replacement Well"). The Commission has also authorized Lockheed Martin to access this site for installation and operation of the Replacement Well. The Replacement Well will henceforth be referred to as well C-1-CW06R. Based on your representations, the Authority understands that well C-1-CW06 will remain in operation until it permanently runs dry and, at that time, will be closed and remediated. The Authority's approval of the Replacement Well and associated access is conditioned on Lockheed Martin complying with the terms set forth in this letter.

Lockheed Martin's installation and operation of the Replacement Well shall at all times comply with the terms of the April 17, 2017 Miscellaneous Properties Memorandum of Understanding ("MOU") between Lockheed Martin and the Authority. This includes Lockheed's indemnification, defense, and remediation obligations with respect to groundwater contamination as of the date the Authority acquired the Airport, Plant C-1, and Lot C. In addition, the following specific conditions apply:

1. Pursuant to Section 5 of the MOU, Lockheed Martin is responsible for disposing of and properly handling all investigation-derived waste.
2. Pursuant to Section 7 of the MOU, Lockheed Martin shall provide a well installation report and all technical data generated by the Replacement Well and well C-1-CW06 to the Authority and the Authority's environmental consultant (currently Tetra-Tech). You

have previously informed the Authority that you will provide all groundwater monitoring data for the Burbank Operable Unit as part of this request.

3. Lockheed Martin will follow the EPA-approved protocol for installation of the Replacement Well.
4. Lockheed Martin will comply with all FAA regulations relating to the Replacement Well installation, including providing a copy of permit applications submitted to the FAA relating to this matter.
5. Pursuant to Section 6 of the MOU, and at its own expense, Lockheed Martin shall follow the closure requirements for well C-1-CW06 once it runs dry. It shall also provide to the Authority a copy of the well's destruction log.
6. Lockheed Martin is responsible for all costs and expenses in connection with locating, drilling, testing and monitoring of well C-1-CW06 and the Replacement Well.

Please do not hesitate to contact me if you have any questions about the conditions applicable to the Commission's approval.

Sincerely,

Frank R. Miller
Executive Director
Burbank-Glendale-Pasadena Airport Authority